

What to Know About LiFePO4 Marine Batteries

I Am a Cruising Sailor Mariner -
Having Sufficient Power Onboard is Important

Tom Trimmer
Custom Marine Products



What to Know About LiFePO4 Marine Batteries

- Overview of LiFePO4 battery technology
- LiFePO4 performance characteristics
- Comparison – lead acid/AGM and LiFePO4
- Designing a LiFePO4 battery bank for your boat
- Installation and operation considerations
- Summary



Slides are available for reference at
custommarineproducts.com

Tom Trimmer
Custom Marine Products
248 705-8337

What is a LiFePO₄ Lithium Iron Phosphate Battery?



**LiFePO Cells
(LFP)**

+



**Battery
Management
System
(BMS)**

+

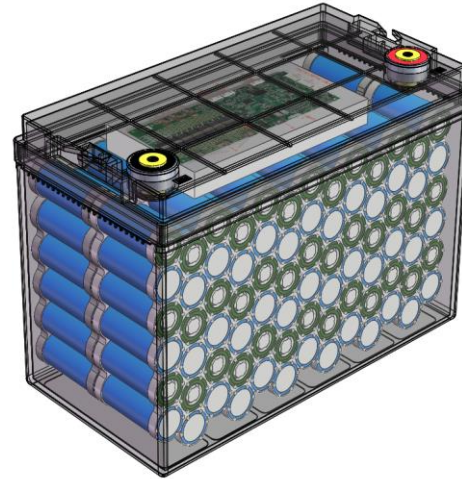

**Sealed
Case**

=



**LiFePO₄
Battery**

Lithium Iron Phosphate (LFP) is a lithium chemistry that has excellent thermal and structural stability (safe) and excellent power density.

Construction of a LiFePO4 battery

Capacity (Ah) 

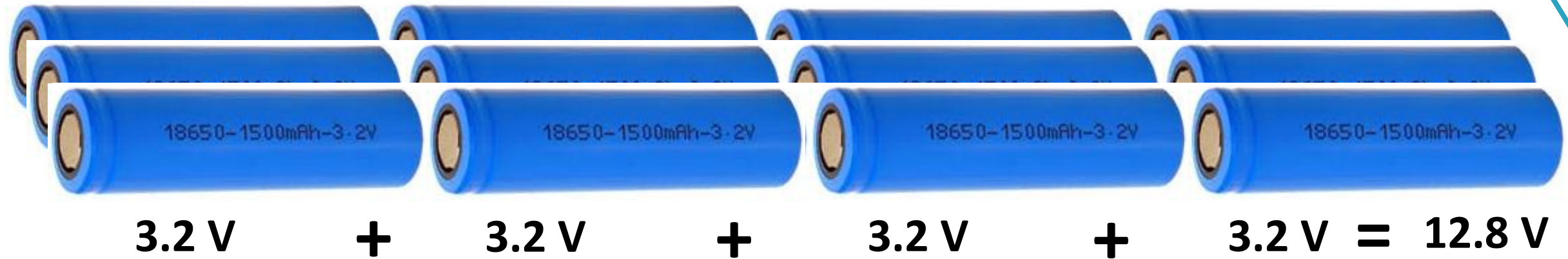

Four groups of cells wired in series = 12.8 Volts

LiFePO₄ is a chemical formula. A single molecule of Lithium Ferro-Phosphate is made up of one Lithium atom, one Iron atom, one Phosphorus atom, and four Oxygen atoms. A Phosphate ion is made up of one Phosphorus atom and **four** Oxygen atoms.



Cylindrical



Prismatic

What is a BMS – Battery Management System?

The BMS regulates the power charge and discharge of the battery and protects the cells from being damaged.

- **Power regulation for cell protection**
 - Over and under voltage monitoring for charge and discharge
 - Low and high temperature during charge and discharge
 - Maximum current draw
 - Short circuit cut off
- **Keeps all cells in balance**
 - Regulates cell charging so all cells maintain the same charge level
- **Generally, enables “drop in” replacement for lead acid and AGM batteries**
- **Monitors and reports battery functions**
 - Some BMS’s report battery State of Charge through a meter or Bluetooth app.

State of Charge (SoC) – Percentage of power remaining in the battery.



LiFePO4 Battery Discharge Curve

Flat rate of discharge:

- Appliances run more efficiently
- 95%+ of rated capacity is usable capacity
- Volt meter does not accurately indicate State of Charge (SoC)

'C' is the rated amp hour (Ah) capacity of the battery

12.8V100Ah Charge-Discharge Curve 0.2C, 25°C

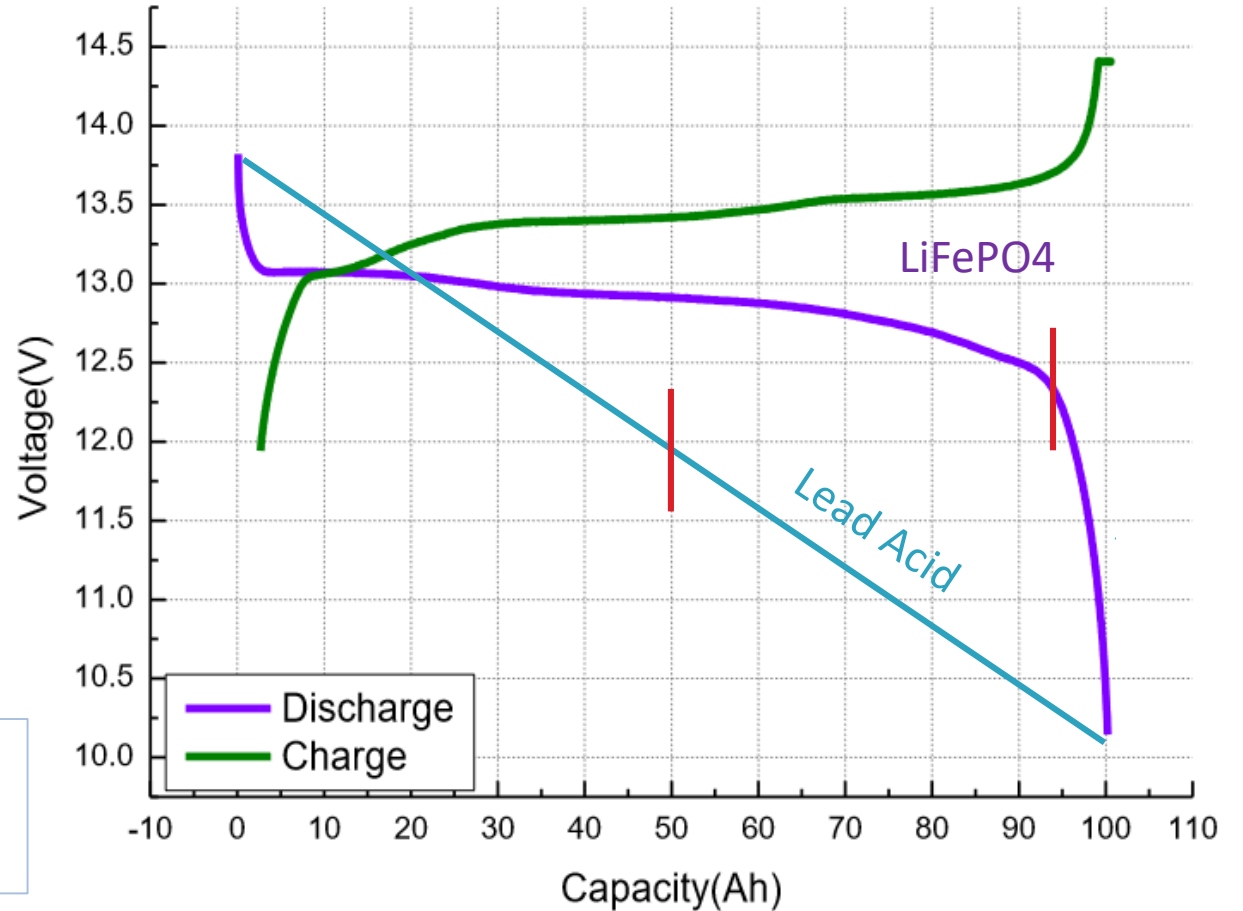

Why is a Bluetooth Battery Monitor Important?

A volt meter is not accurate because the discharge voltage is nearly constant.

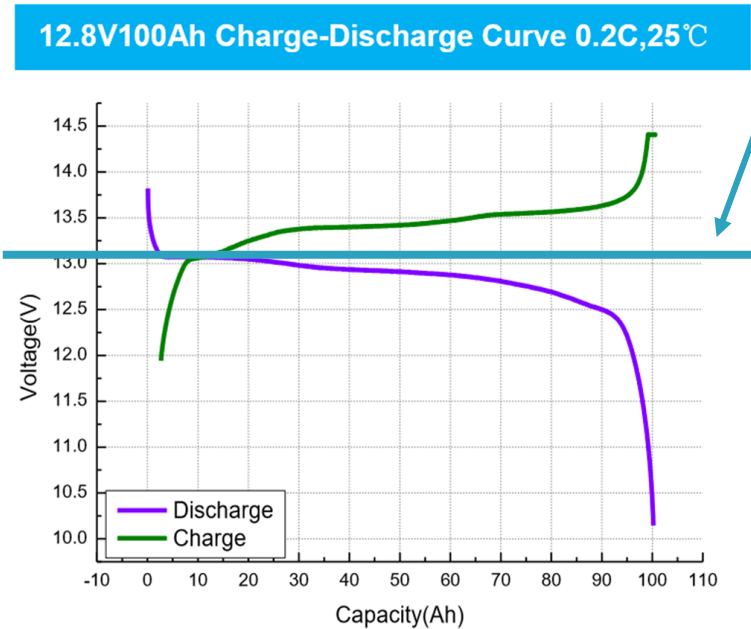

An app connected directly to the BMS provides better accuracy than external measuring systems.



Will a Traditional Battery Monitor Report an Accurate SoC?

Yes - close, with a bit of reprogramming

- Battery monitors compute the SoC of a battery bank by measuring the electrical energy (coulombs) crossing over a shunt (bridge).
- Most battery monitors are designed for monitoring lead acid and AGM batteries. They use a Peukert coefficient to compensate for battery charge/discharge inefficiency.
- The Peukert coefficient must be changed from the default (1.2 – 1.5) to 1.04 (ish) for the battery monitor to be accurate.

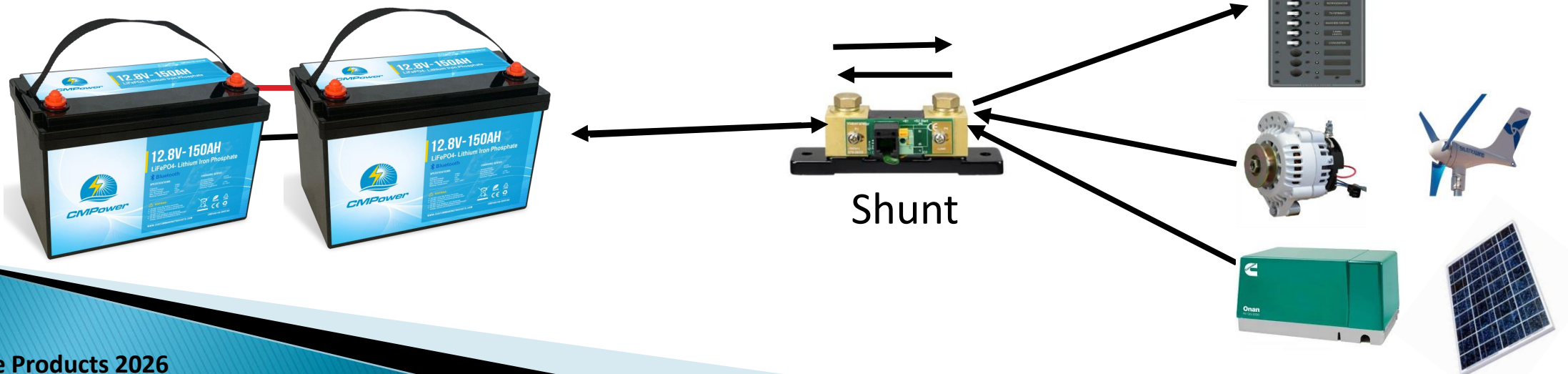

Battery Charging Curves

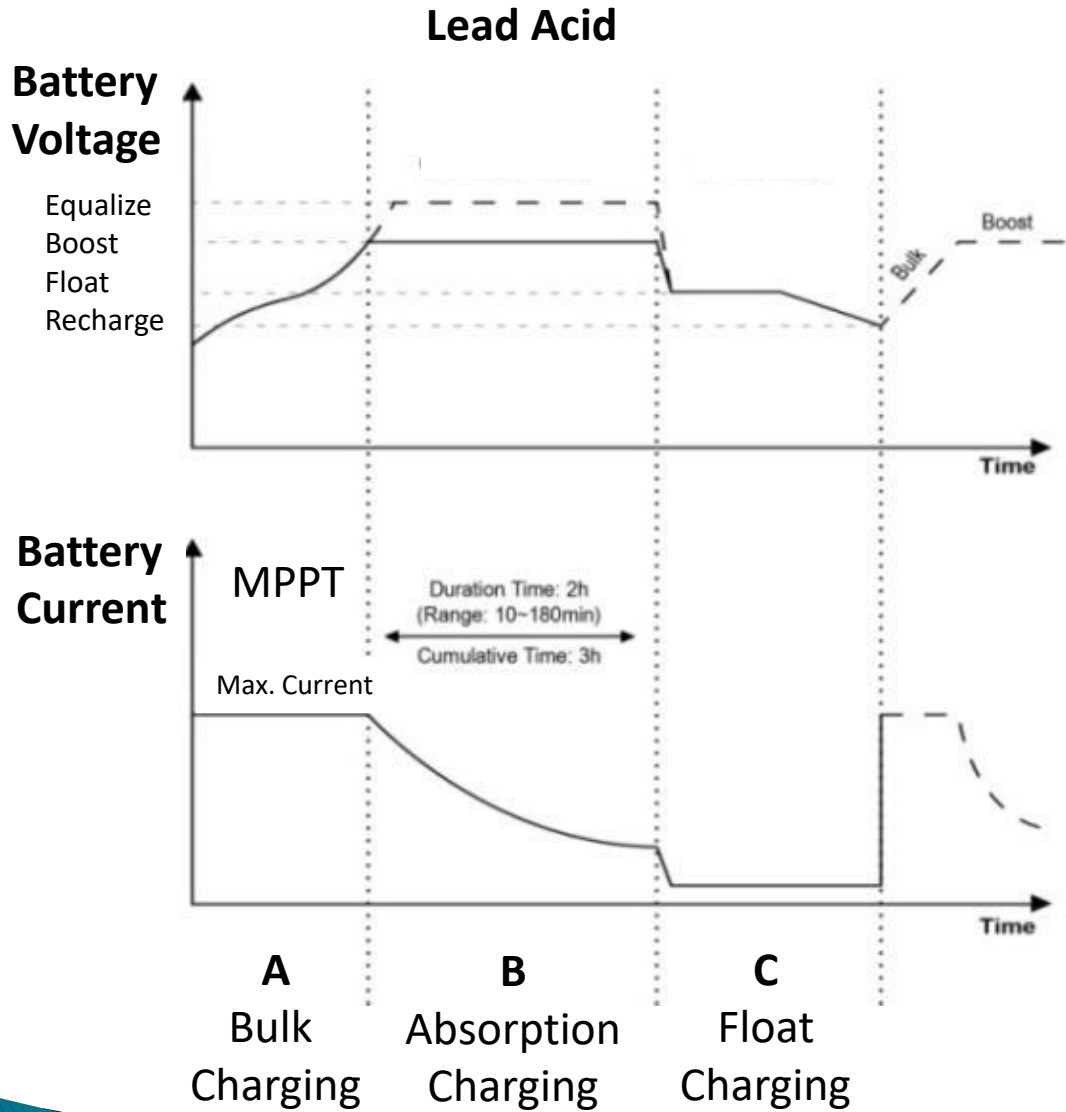

EP Solar

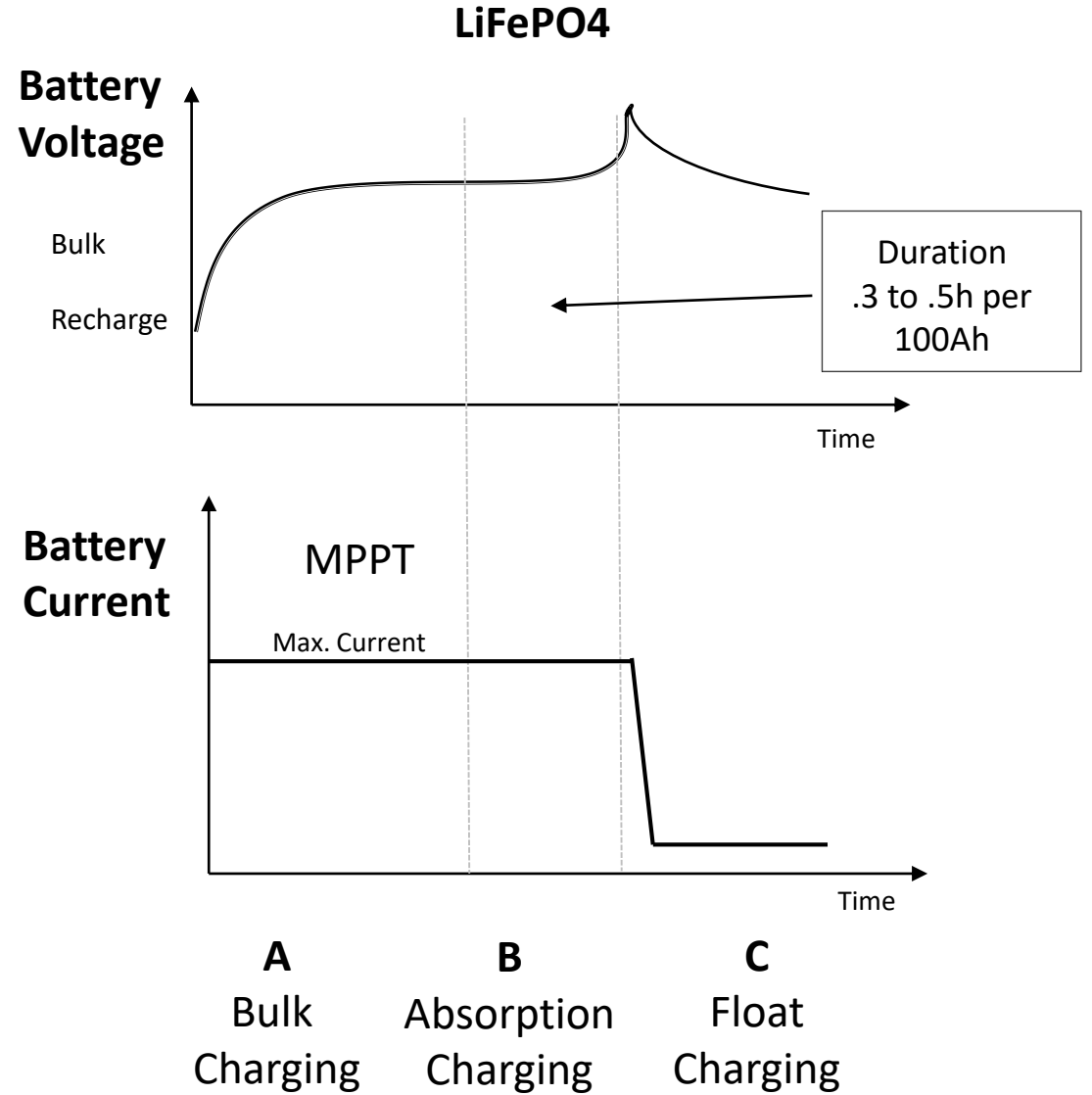

CMPower

LiFePO4 Battery Performance Characteristics

12.8 V 100 Ah LiFePO4 Battery

Capacity (% rated)

Charging Characteristics @ 0.5 C 25°C

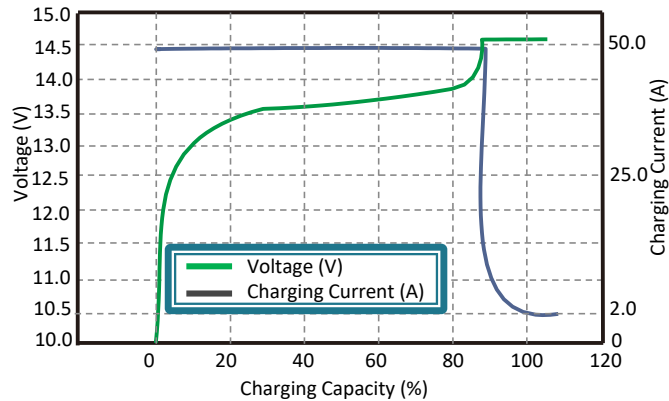

Rate of Discharge Curves @ 25°C

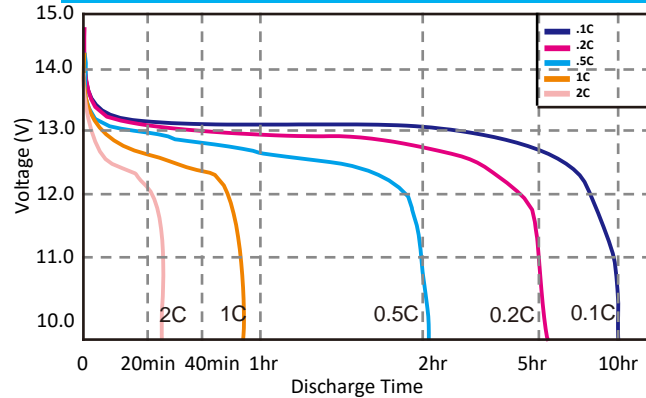

Depth of Discharge Cycle Life @ 1C

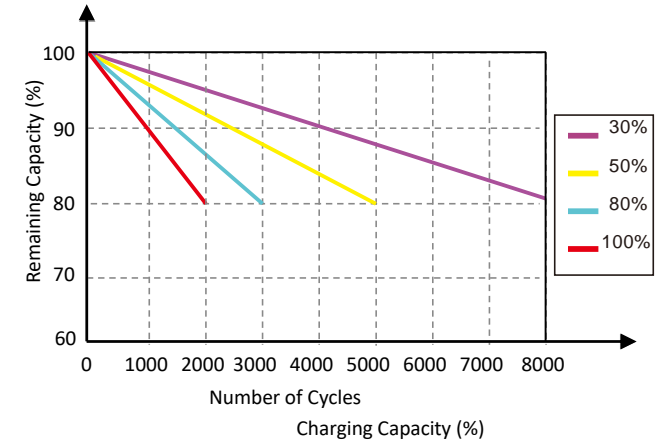

State of Charge @ 0.5 C 25°C

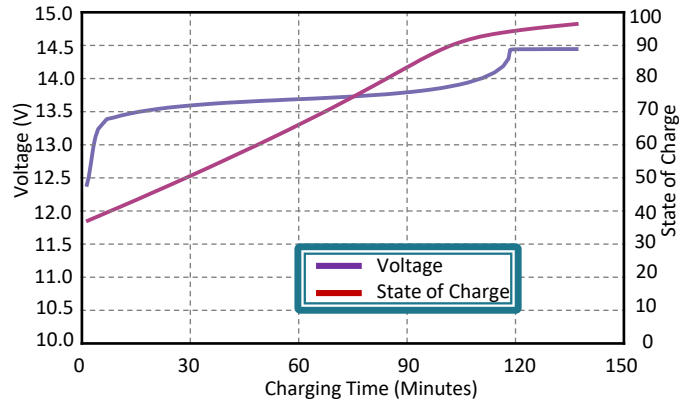

Temperature Discharge Curves @ 0.5C

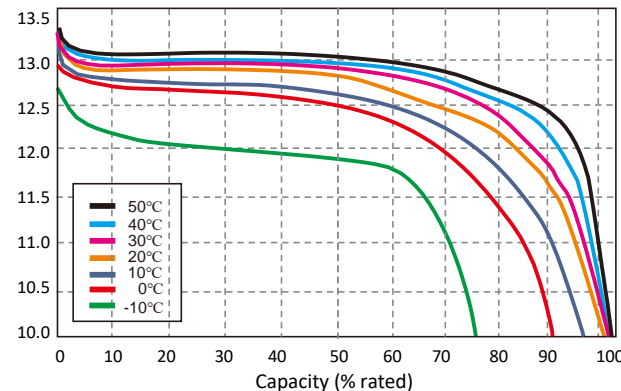

Temperature - Self Discharge

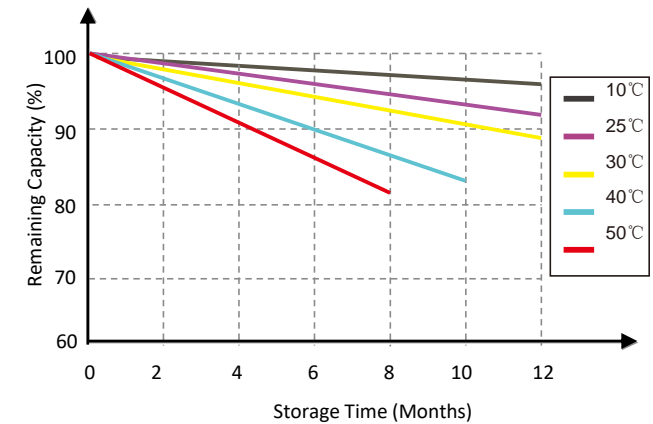

'C' is the rated amp hour (Ah) capacity of the battery

Temperature Impact on Battery Life

Cycling at high charge/discharge rates at extreme temperatures will reduce the number of life cycles, especially at low temperatures.

Charge Temperature	32°F to 113°F	0°C to 45°C	
Discharge Temperature	-4°F to 140°F	-20°C to 60°C	
Storage Temperature	-10°F to 104°F	-25°C to 40°C	

Charging and discharging a LiFePO4 battery does not generate significant heat within the battery.

What is a Charge Cycle?

- For a 100 Ah battery, a charge cycle is logged when a cumulative 100 Ah are charged/discharged.
- For example: If a battery is discharged by 20 Ah and recharged 5 times, that is a cumulative total of 100 Ah and 1 cycle is logged and reported by the BMS.

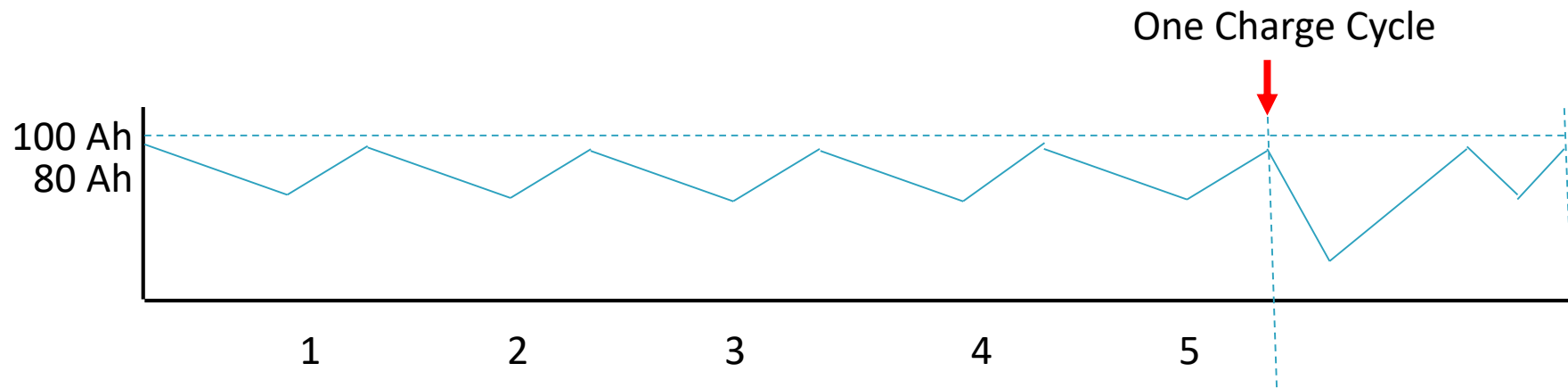

Example of LiFePO4 Battery Specifications – 100 Ah 12.8 V

Electrical Characteristics	Nominal Voltage	12.8V
	Nominal Capacity	100Ah
	Energy	1,280 Wh
	Internal Resistance	≤20mΩ
	Cycle Life	>2000 cycles @1C 100% DOD, >3000 cycles @1C 80% DOD
	Months Self Discharge	<3%
	Efficiency of Charge	100% @0.5C
	Efficiency of Discharge	96~99% @1C
Standard Charge	Charge Voltage	14.4±0.1V
	Charge Mode	0.2C to 14.4V, then 14.4V,charge current to 0.02C (CC/CV)
	Charge Current	20-50A
	Max Charge Current	100A
	Charge Cut-off Voltage	14.6V±0.1V
Standard Discharge	Continuous Current	150A
	Max. Pulse Current	300A(<3s)
	Discharge Cut-off Voltage	10V
Environmental	Charge Temperature	0 °C to 45 °C (32F to 113F) @60±25% Relative Humidity
	Discharge Temperature	-20 °C to 60 °C (-4F to 140F) @60±25% Relative Humidity
	Storage Temperature	0 °C to 40 °C (32F to 104F) @60±25% Relative Humidity
	Water Dust Resistance	IP56
Mechanical	Cell & Method	32700 6000mAH
	Plastic Case	ABS+PC UL V-0 flame resistant
	Dimensions (mm./in.)	L340*W170*H210mm / L13.4*W6.7*H8.3 in.
	Weight (kg./lbs.)	14kgs/31lbs.
	Terminal	M8
	Features	Bluetooth battery monitor app

Comparison of Lead Acid vs. LiFePO4 - 100Ah Battery

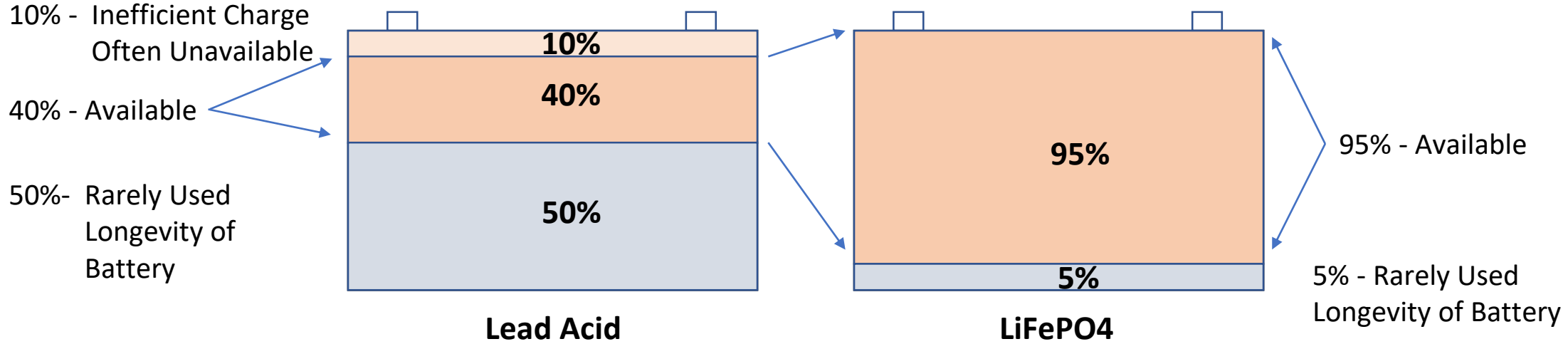

Useable Amp Hours

40-50 Ah

90 - 95 Ah

Ah - Amp hours

(Today 150 Ah)

Comparison of Lead Acid vs. LiFePO4 - 100Ah Battery

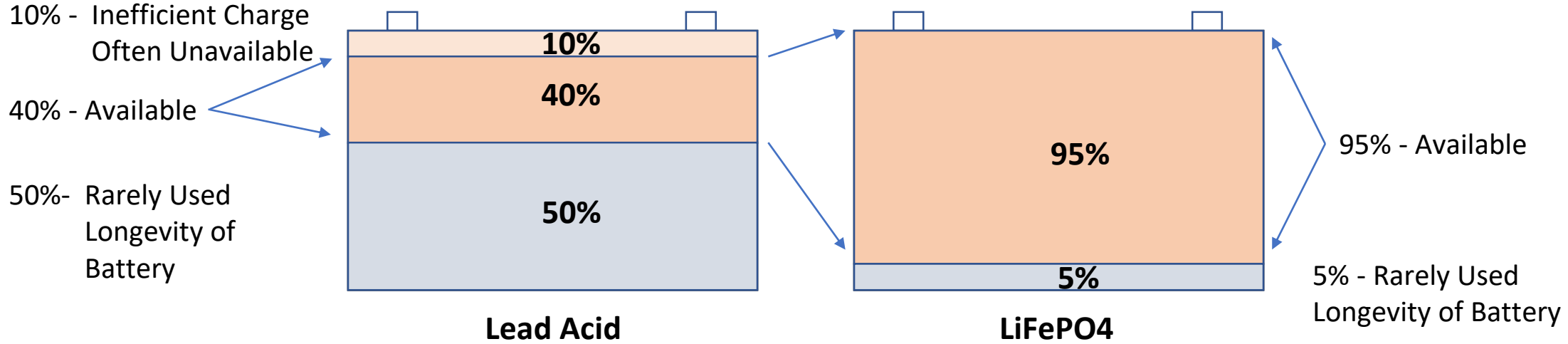

Useable Amp Hours	40-50 Ah	90 - 95 Ah
Weight	65 lbs.	31 lbs.

lbs. - pounds

Comparison of Lead Acid vs. LiFePO4 - 100Ah Battery

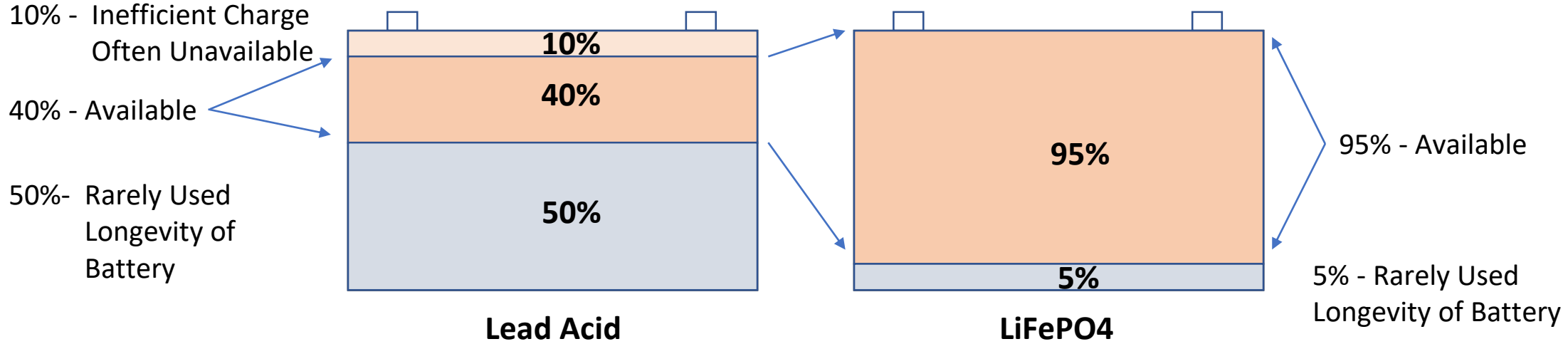

Useable Amp Hours	40-50 Ah	90 - 95 Ah
Weight	65 lbs.	31 lbs.
Energy Density	9 Wh/lb.	39 Wh/lb.

Wh – Watt hours

Comparison of Lead Acid vs. LiFePO4 - 100Ah Battery

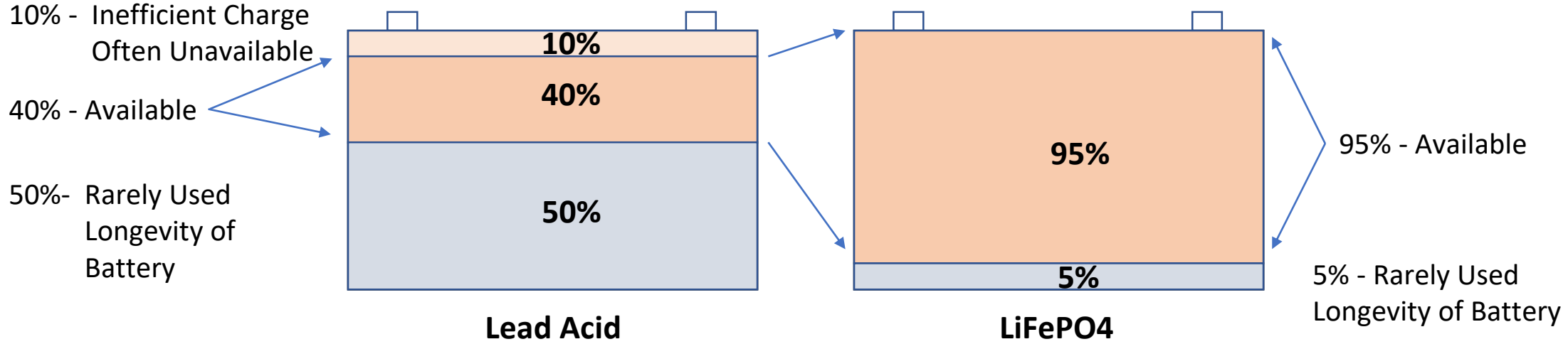

Useable Amp Hours	40-50 Ah	90 - 95 Ah
Weight	65 lbs.	31 lbs.
Energy Density	9 Wh/lb.	39 Wh/lb.
Charge/discharge Cycles	<400	>3,000

Cost per charge cycle: SLA \$1 LiFePO4 \$.15

Comparison of Lead Acid vs. LiFePO4 - 100Ah Battery

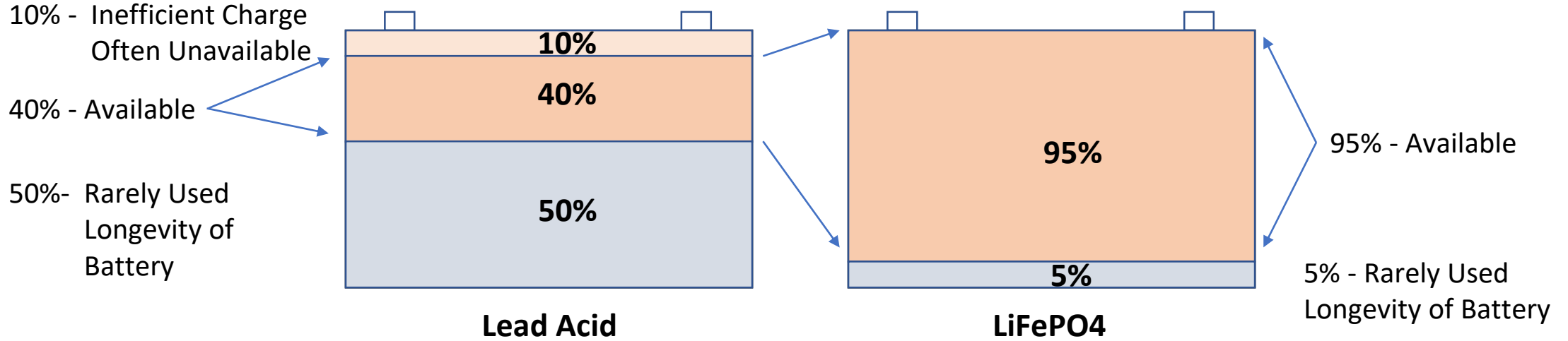

	Lead Acid	LiFePO4
Useable Amp Hours	40-50 Ah	90 - 95 Ah
Weight	65 lbs.	31 lbs.
Energy Density	9 Wh/lb.	39 Wh/lb.
Charge/discharge Cycles	<400	>3,000
Charge Efficiency	70-80%	99%

A 20% greater charge efficiency means 20% more power is stored.
 Example: 100 Ah charge: 80% efficient = 80 Ah stored, 99% efficient = 99 Ah stored

Comparison of Lead Acid vs. LiFePO4 - 100Ah Battery

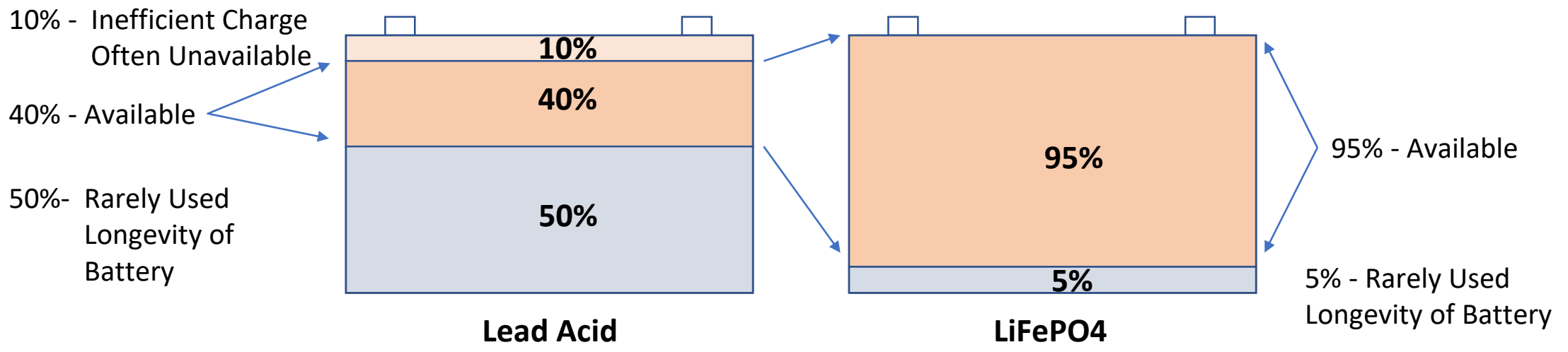

Useable Amp Hours	40-50 Ah	90 - 95 Ah
Weight	65 lbs.	31 lbs.
Energy Density	9 Wh/lb.	39 Wh/lb.
Charge/discharge Cycles	<400	>3,000
Charge Efficiency	70-80%	98%
Self Discharge	up to 20% / mon.	<3% / mon.

The Case of the Listing Oyster 66



Rolls Surette Lead Acid
 12V 210 Ah
 2-series, 5 sets in parallel

CMPower
 24V 150 Ah
 4 in parallel

Useable Amp Hours @ 24V	525 Ah	600 Ah	+75 Ah
Weight	1,350 lbs.	320 lbs.	-1,030 lbs.

What was the extra space in the battery compartment used for?

Summary of LiFePO₄ Battery Advantages

- **Bluetooth Battery Monitor** - Built-in real-time monitoring of battery State-of-Charge
- **Longer Cycle Life** - Up to 10 times longer cycle life and 5 times longer calendar life than lead acid batteries.
- **Lighter Weight** - Up to 50% lighter than a comparable lead acid battery.
- **High Energy Density** – Up to 5 times more power per pound than lead acid batteries.
- **Efficient Charging and Discharging** - Up to 20% more efficient. Store 20% more generated charging power.

Summary of LiFePO₄ Battery Advantages

- **Superior Safety** - High thermal and chemical stability. LiFePO₄ chemistry eliminates the risk of combustion due to overcharging, short circuit, high impact, or noxious gasses.
- **Increased Flexibility** - Modular design enables deployment of up to 4 batteries in series and up to 10 batteries in parallel.
- **Compatibility** - The BMS (Battery Management System) compensates for various charging profiles and protects the LiFePO cells.
- **Near Constant Discharge Voltage** – full power (13.2V) until discharged
- **Low Discharge Rate** – limited power loss in storage

Summary of LiFePO4 Battery Disadvantages

- **Temperature Range** - Should not be charged or discharged below -4 F, -20 C
- **Cost** - High initial investment
- **Charging Equipment** - May require modification of some charging equipment
- **Alternator Protection** – Rapid battery shut down by BMS at full charge could injure the alternator diodes and create a voltage spike.
- **Alternator Overheating** - The charging alternator may overheat because the LiFePO4 batteries will absorb more power than AGMs.
- **Battery Balancing** - Some Battery Management Systems (BMS) handle balancing of batteries wired in parallel poorly.
- **Insurance Coverage** – Some insurance companies will not underwrite boats with LiFePO4 batteries.

Designing a LiFePO₄ battery bank for your boat

Designing a Marine Power System

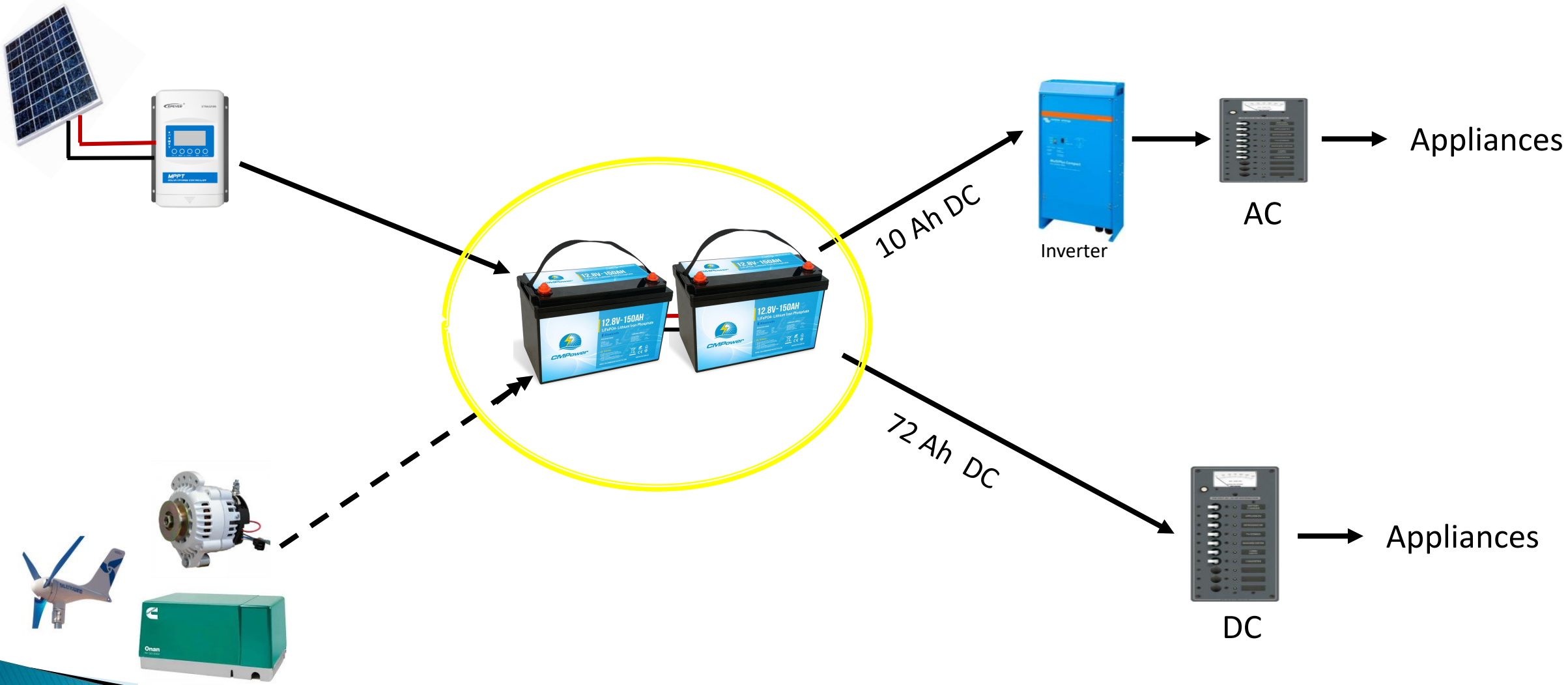

Worksheet for Designing a Solar System Based on Power Consumption

Design

Input fields in Grey

Worksheet for Designing a Solar System Based on Power Consumption						Input fields in Grey			
1. Daily Power Consumption Analysis									
Appliance	Amps	Hours		Daily AH *1*	Daily AH				
		At Anchor	On Passage	At Anchor	On Passage				
Refrigerator	5	10	10	50	50				
Radar	4		4	0	16				
Computer - Laptop	4	1	10	4	40				
Autopilot	4		10	0	40				
Cabin Lights (LED)	1	4		4	0				
Navy Anchor Lights	0.2	10	10	2	2				
Stereo	1	3	3	3	3				
VHF Radio	0.5	10	10	5	5				
Instruments	1		8	0	8				
Pressure Water	6	0.25	0.1	1.5	0.6				
Phone Charger	1	2	2	2	2				
Other				0	0				
Other				0	0				
Windlass *2*				0	0				
Total Amp Hours				71.5	166.6				
AC - Equipment powered by an Inverter (Watts)									
	Watts	Hours	Hours	AH	AH				
Microwave (Watts)	1100	0.1	0.1	10.2	10.2				
Other				0.0	0.0				
Other				0.0	0.0				
Other				0.0	0.0				
Other				0.0	0.0				
Total Amp Hours				10.2	10.2				
Total Amp Hours Consumed per Day				81.7	176.8				
Battery Charging Voltage				13					
Total Watt Hours Consumed per Day				1,061.5	2,297.8				
2. Alternative Power Sources									
Alternator	30		2	0	60				
Generator				0	0				
Other				0	0				
Total Amp Hours				0	60				
Total Watt Hours Produced per Day				0	780				
Net Watt Hours per Day Consumed or Produced				1,061.50	1,517.80				
Custom Marine Products						custommarineproducts.com			
info@custommarineproducts.com						248 705-8337			
3. Solar Power Requirement Analysis (Full Sun)								At Anchor	On Passage
Average Hours of Sun per Day						5	*3*		
Battery Charge Inefficiency Factor						1.2	*4*		
Watts of Solar to Replenish Battery Bank Daily						254.8		364.3	
Solar System Design Analysis (MPPT Controller)									
Capacity of Each Solar Panel (Watts)						130			
Number of Solar Panels Required						2.2		3.1	
Number of Solar Panels Installed						3			
Minimum Capacity of Solar Controller (Amps)						30.0			
Daily Useable Solar Power in Full Sun (Watt Hrs)						1,560.0			
Daily Power Drawn from Battery Bank (Watt Hrs)								1,061.5	1,517.8
Excess or (Deficit) of Power (Watt Hrs)								498.5	42.2
4. Factor for Cloudy Days									
Solar Efficiency on Cloudy Days (percentage)						30%	*5*		
Solar Power Generated on a Cloudy Day						468.0			
Power Drawn from Batteries on a Cloudy Day (Wh)								593.5	1,049.8
Number of Continuous Cloudy Days						2			
Sunny Days to Make Up Battery Draw Down						2.4		49.8	
5. Battery Capacity Analysis								Amp Hrs	Amp Hrs
								at Anchor	on Passage
Scenario 1 - Based on Cloudy Days - with Solar									
Ah Drawn from Batteries on Cloudy Days								91.3	161.5
% of Battery Capacity Useable						50%	*6*		
Rated Battery Capacity Required (AH)								182.6	323.0
Rated Battery Capacity (Ah)						120			
Number of Batteries Required (in parallel)								1.5	2.7
Scenario 2 - Based on Days of Reserve Capacity (no solar)									
Number of Days of Reserve Battery Capacity						2			
% of Battery Capacity Useable						50%			
Rated Battery Capacity Required (AH)								326.6	467.0
Rated Battery Capacity (Ah)						120			
Number of Batteries Required (in parallel)								2.7	3.9
1 AH - Amp Hours - Amps of current consumed in one hour									
2 Windlass is often not considered because the engine alternator is running when used									
3 5 hours avg. is a good estimate for horizontal panels, 7 for panels with tilt & rotate See http://www.bigfrogmountain.com/SunHoursPerDay.html for hours in your area.									
4 Charge efficiency factor - Lead Acid ≈ 1.2, AGM ≈ 1.1, LiFePO4 ≈ 1.04									
5 Solar efficiency - Partly cloudy ≈ 70%, Mostly cloudy ≈ 50%, Very cloudy ≈ 30%									
6 Useable battery capacity - Lead Acid ≈ 50%, AGM ≈ 60%, LiFePO4 ≈ 95%									

Available at:
custommarineproducts.com
 - Handy Info - System Design

Designing a LiFePO4 Battery Bank for Your Boat

1. Estimate daily power consumption

1 AH - Amp Hours - Amps of current consumed in one hour

2 Windlass is often not considered because the engine alternator is running when used

Note:

1,100 watts / 13 volts x 1.2 inverter inefficiency factor

Appliance	Amps	Hours		Daily AH *1*	
		At Anchor	On Passage	At Anchor	On Passage
Refrigeration		10	10	50	50
Radar	4		4	0	16
Computer - Laptop	4	1	10	4	40
Autopilot	4		10	0	40
Cabin Lights (LED)	1	4		4	0
Nav/Anchor Lights	0.2	10	10	2	2
Stereo	1	3	3	3	3
VHF Radio	0.5	10	10	5	5
Instruments	1		8	0	8
Pressure Water	6	0.25	0.1	1.5	0.6
Phone Charger	1	2	2	2	2
Other				0	0
Other				0	0
Windlass *2*				0	0
Total Amp Hours				71.5	166.6
AC - Equipment powered by an Inverter (Watts)					
	Watts	Hours	Hours	AH	AH
Microwave (Watts)	1100	0.1	0.1	10.2	10.2
Other				0.0	0.0
Other				0.0	0.0
Other				0.0	0.0
Other				0.0	0.0
Total Amp Hours				10.2	10.2
Total Amp Hours Consumed per Day				81.7	176.8
Battery Charging Voltage			13		
Total Watt Hours Consumed per Day				1,061.5	2,297.8
2. Alternative Power Sources					
Alternator	30		2	0	60
Generator				0	0
Other				0	0
Total Amp Hours				0	60
Total Watt Hours Produced per Day				0	780
Net Watt Hours per Day Consumed or Produced				1,061.50	1,517.80

Designing a LiFePO4 Battery Bank for Your Boat

Net Watt Hours per Day Consumed or Produced		1,061.50	1,517.80
---	--	----------	----------

LiFePO4

		At Anchor	On Passage
Number of Days of Reserve Battery Capacity	2		
% of Battery Capacity Useable	95%		
Rated Battery Capacity Required (AH)		171.9	245.8
Rated Battery Capacity (Ah)	120		
Number of Batteries Required (in parallel)		1.4	2.0

2 2

- Estimate the days of reserve capacity desired
- Determine optimal useable battery capacity
- Determine the capacity of the batteries to be used
- Calculate the number of batteries needed

Lead Acid

		At Anchor	On Passage
Number of Days of Reserve Battery Capacity	2		
% of Battery Capacity Useable	50%		
Rated Battery Capacity Required (AH)		326.6	467.0
Rated Battery Capacity (Ah)	120		
Number of Batteries Required (in parallel)		2.7	3.9

3 4

Effectively Utilize Solar Power in a Balanced System

(No Solar)

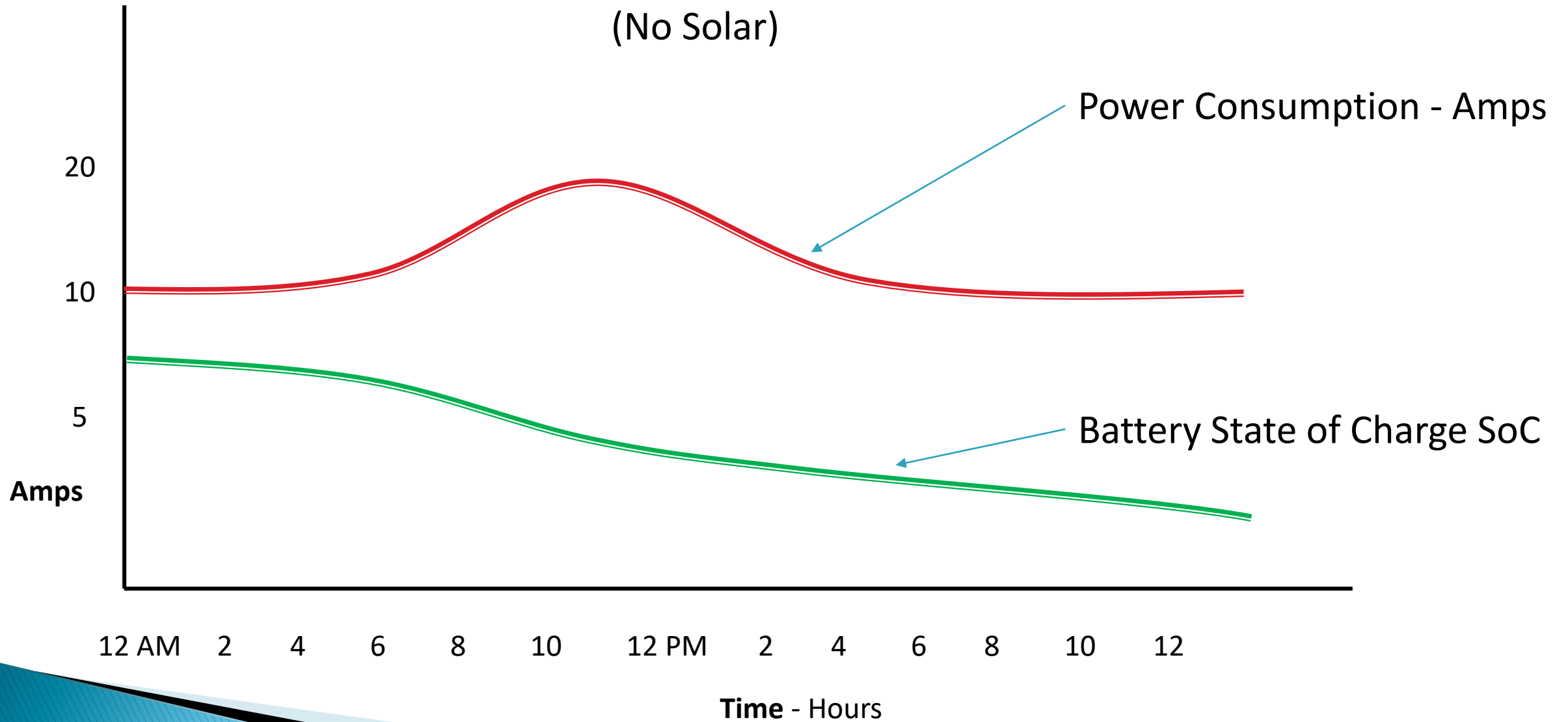

Effectively Utilize Solar Power in a Balanced System

(With Solar)

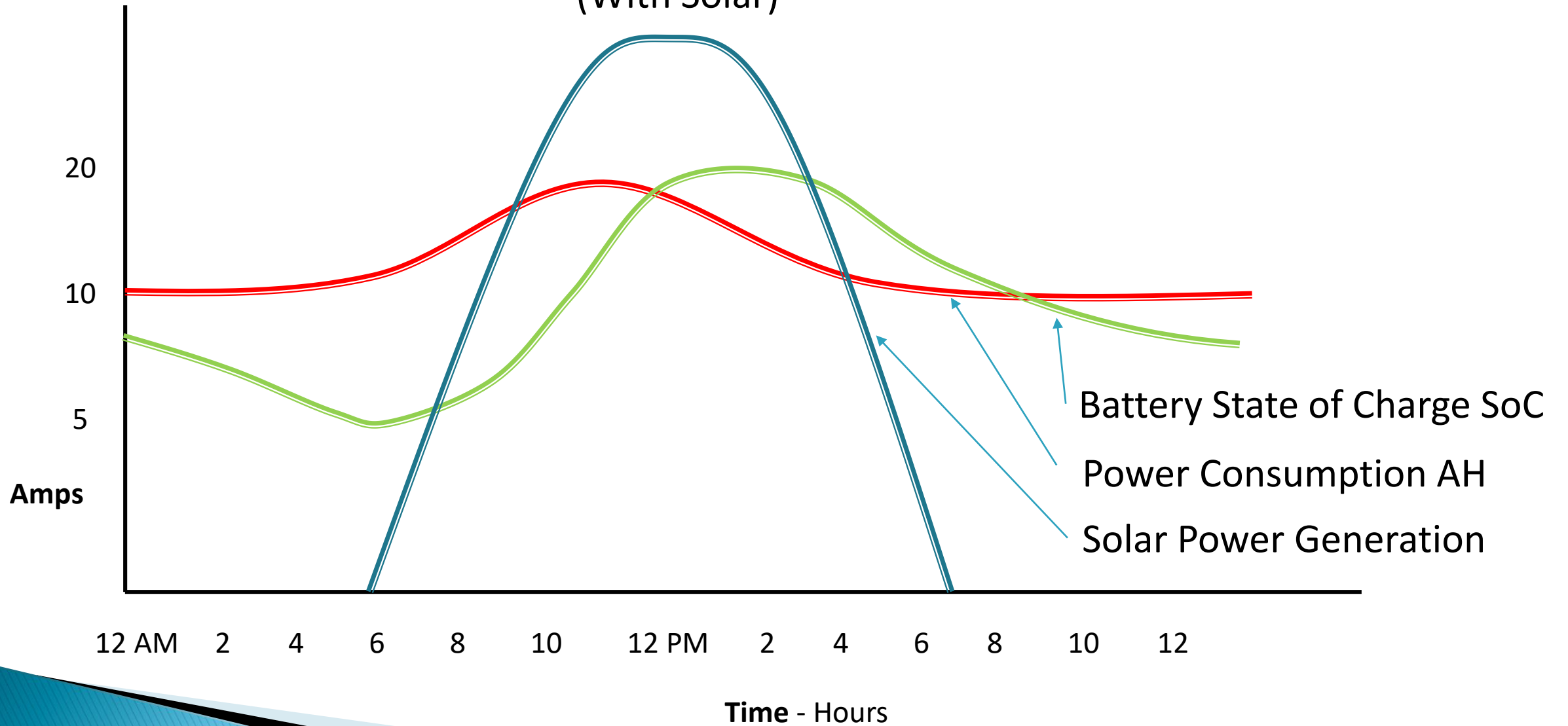

Effectively Utilize Solar Power in a Balanced System

(With Solar)

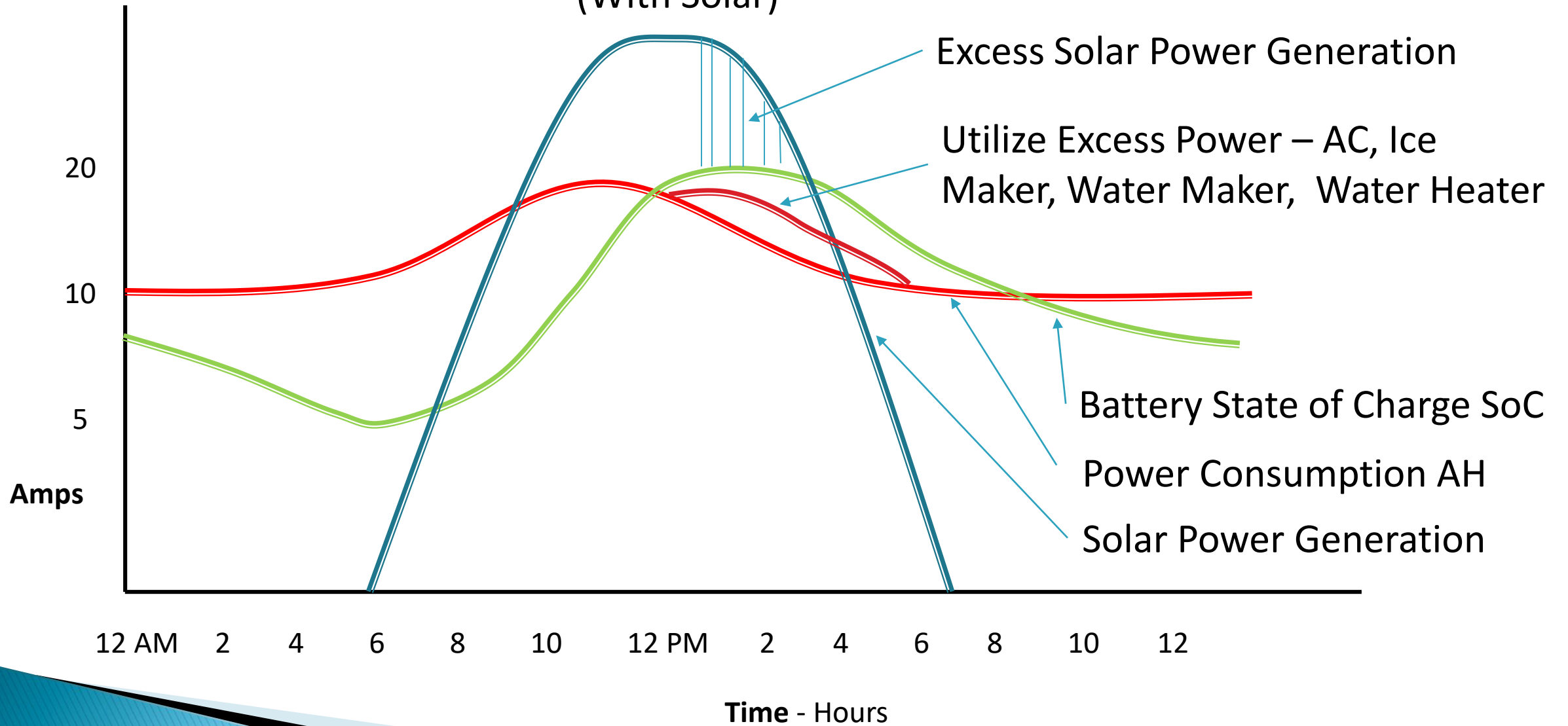

Installation and operation considerations

Wiring a Battery Bank

Battery Specifications

Capacity	100 Ah
Voltage	12 V
Continuous Current	100 A

Parallel

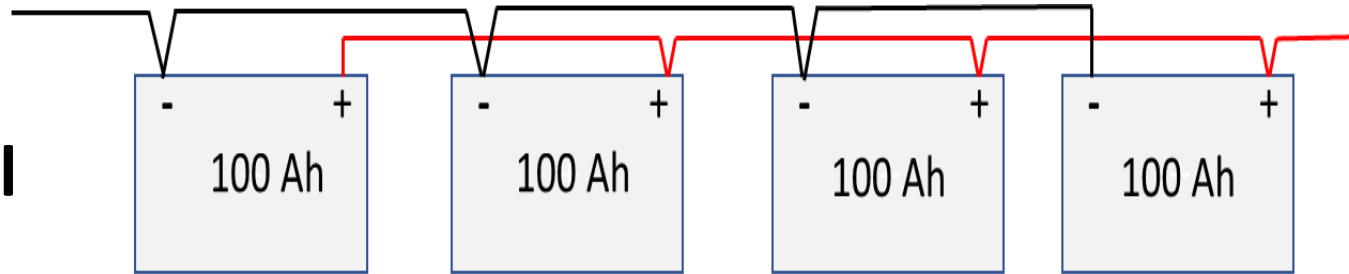

12V 400 A Continuous Current - 360 Ah Capacity at 90%

Series

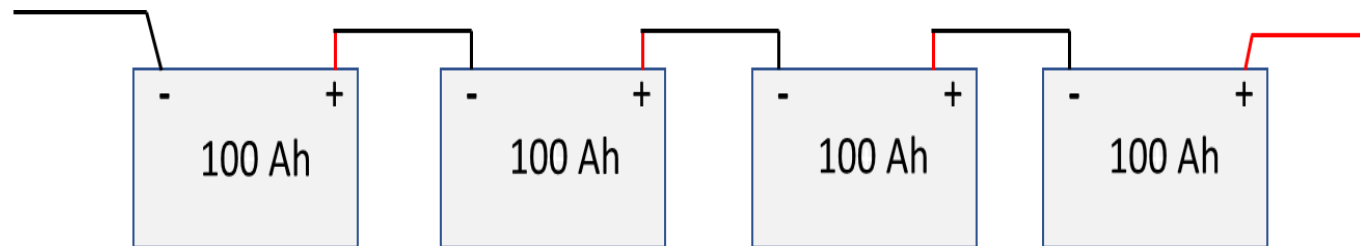

48V 100 A Continuous Current - 90 Ah Capacity at 90%

The **CMPower** BMS will support 10 batteries in parallel and 4 batteries in series.

Wire batteries together only when their SoC is within 5% for each battery.

The Dilemma of Multiple Battery Types Onboard

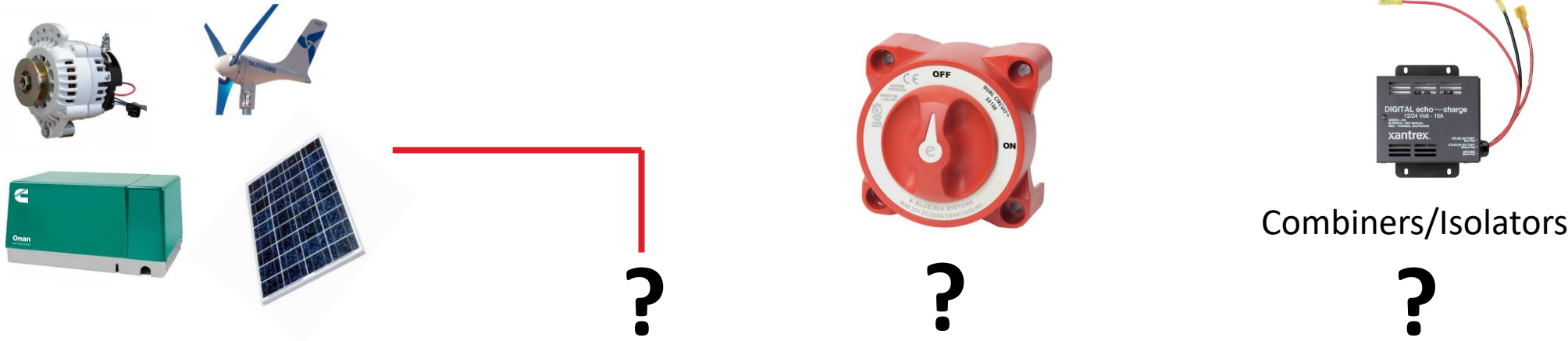

Start
(Lead Acid)



House
(LiFePO4)



**Thruster
Generator Start**
(Lead Acid, AGM)

Never combine different types or sizes of batteries.

Multiple Battery Types Onboard – Wiring a Battery Isolator

Battery Isolator vs a Battery Combiner

Advantage – multiple batteries can be charged independently.

Disadvantage – only one battery charging profile.



Victron ARGO FET Battery Isolator

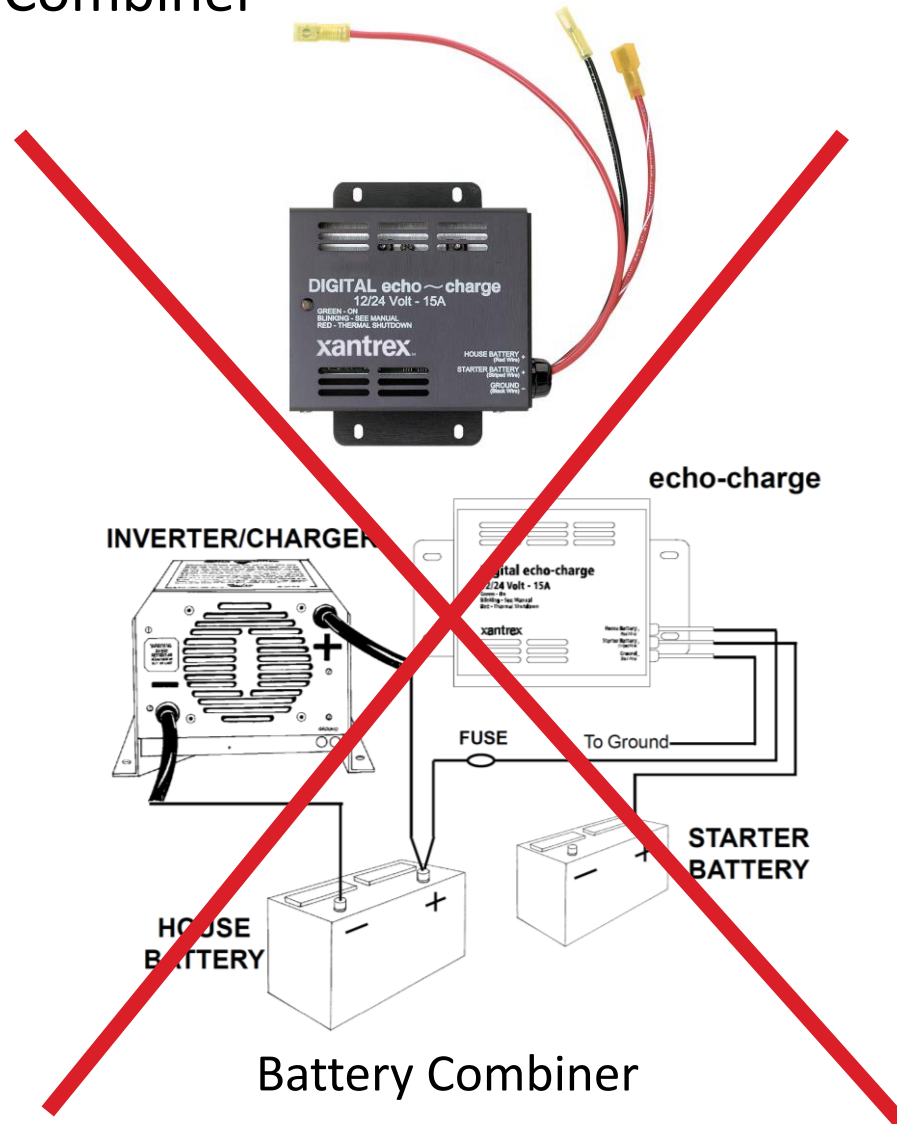
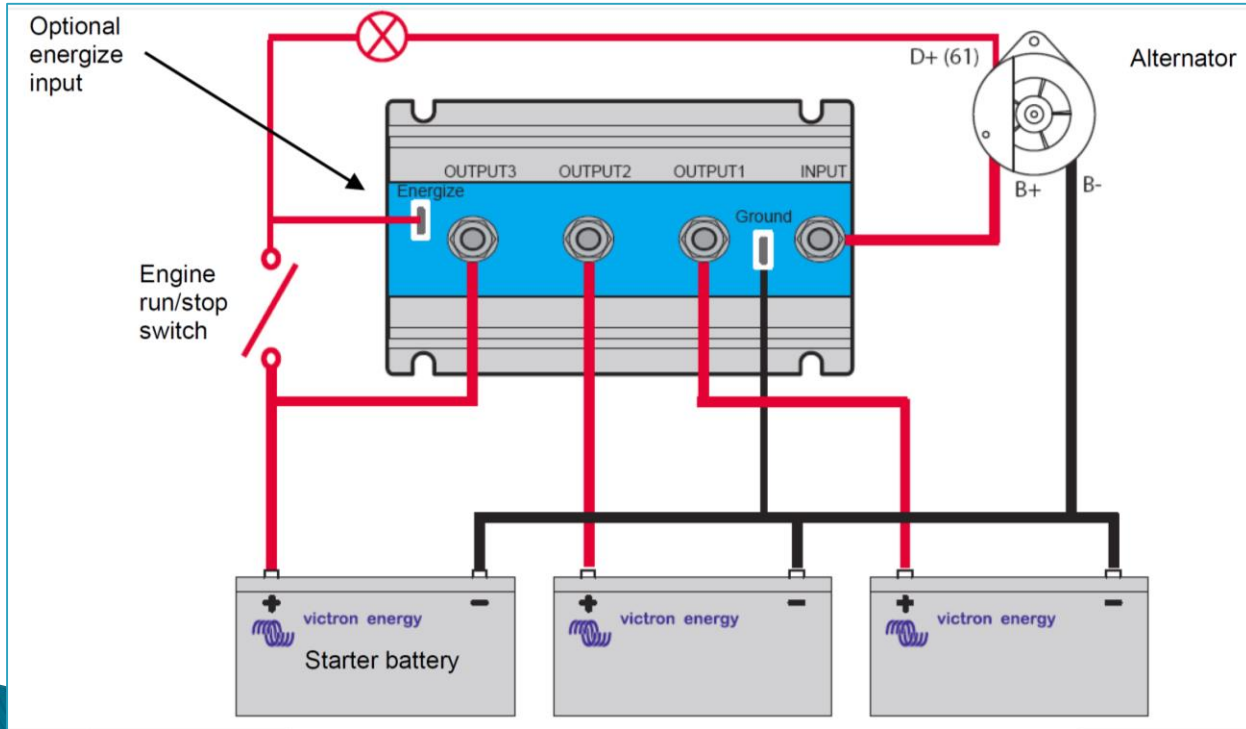

Never combine different types or sizes of batteries.

Multiple Battery Types Onboard – DC-DC Charger

For use in dual battery systems where the alternator and the start battery are used to charge the service/house battery bank.

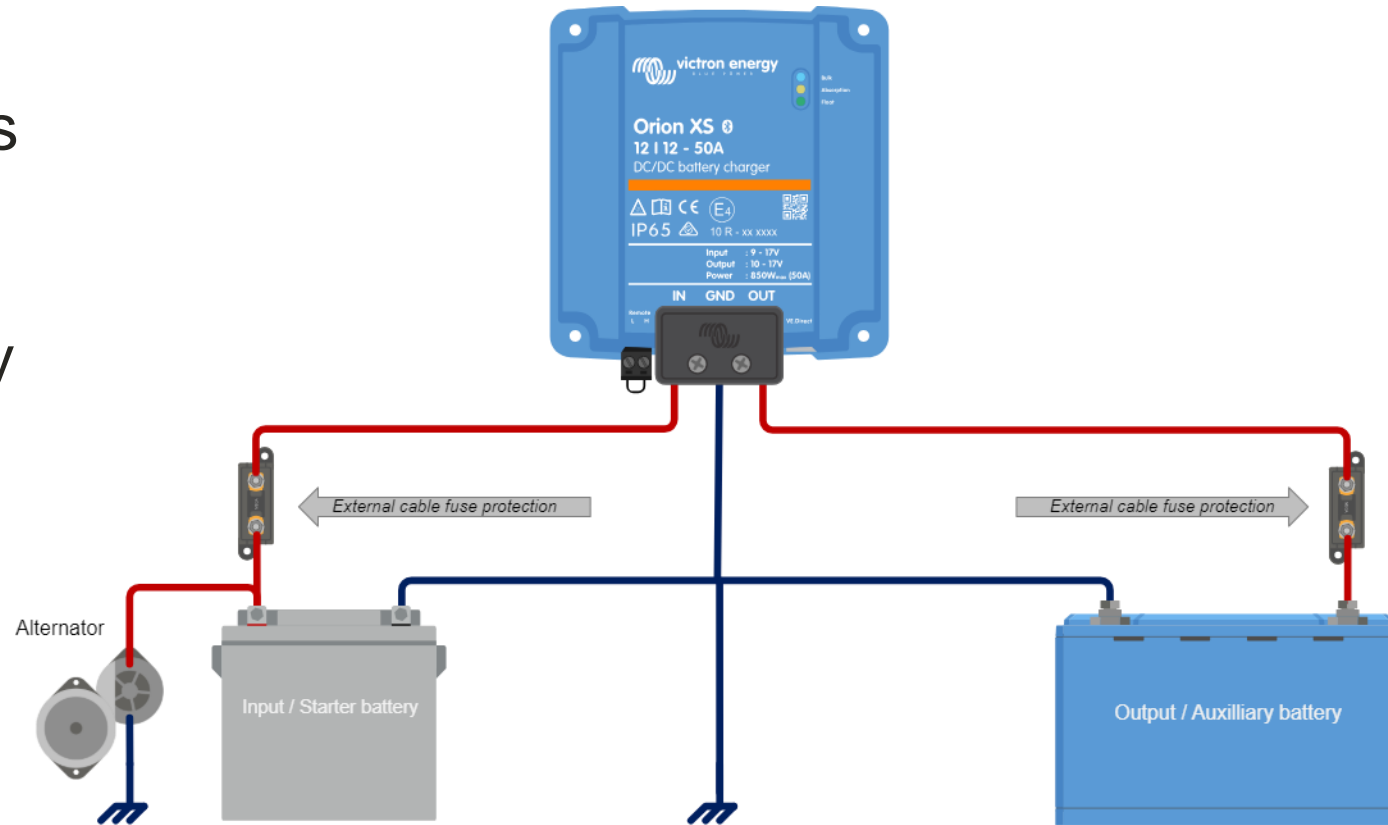

Advantages

- Multiple batteries can be charged independently.
- Multiple battery charging profiles.
- Easy to install and monitor
- Protects the alternator
- Multiple Orion units can be wired in parallel for higher power charging.

Multiple Battery Types Onboard

Dual Output Solar Controller

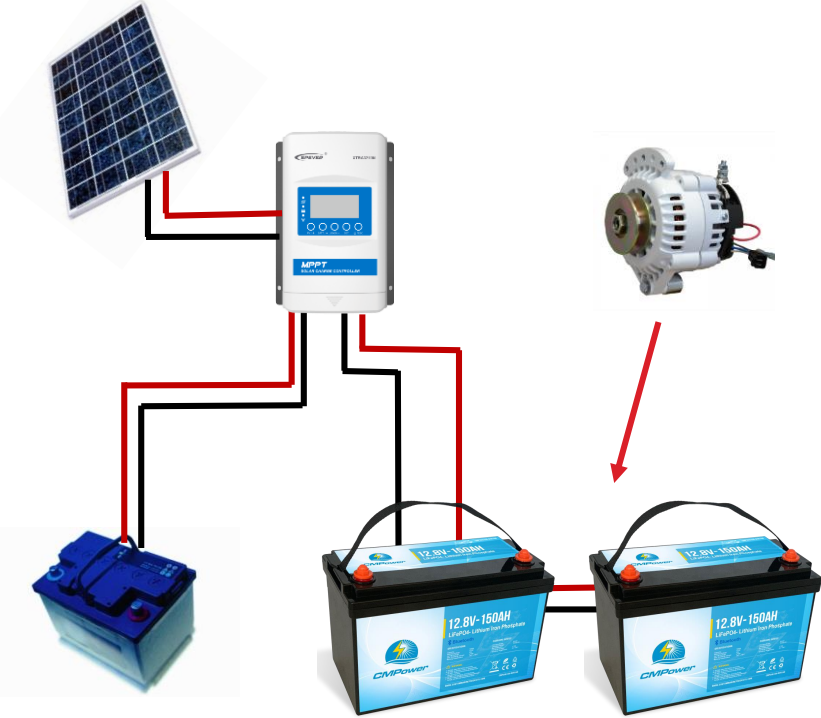

Start
(Lead Acid)

House
(LiFePO4)

Single Battery Bank

Features that enable single bank operation:

- 150-200A Continuous Draw BMS
- Bluetooth monitoring
- Low battery alarm



House &
Start

Emergency
Only

Never combine different types or sizes of batteries.

Alternator Protection

- Abrupt interruption of a load on the alternator can cause a voltage spike that could damage the alternator and possibly damage sensitive electronic equipment.
- Such an interruption could occur when the battery BMS shuts off from high voltage or during switching between battery banks.
- A Sterling Power Alternator Protection Device (APD) absorbs the voltage spike and protects the alternator. Cost <\$90.
- Not all BMS's do abrupt cutoff. Batteries wired in parallel will likely have staggered high voltage cutoff mitigating the issue.

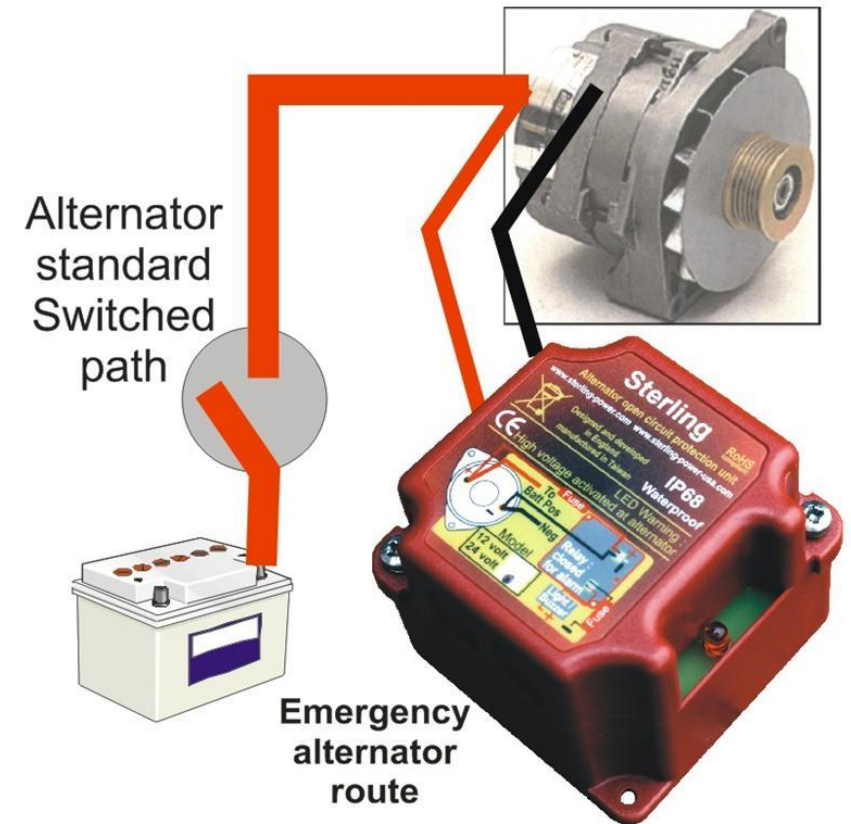

Installation Considerations

- Batteries can be mounted on bottom or any side.
- Batteries should be mounted in a moderate temperature environment.
 - not in the engine room unless well ventilated
- Charging parameters for charging sources may need to be adjusted.
 - max voltage, min voltage cut off, etc.
- Alternator loading – Efficient charging of LiFePO₄ batteries may result in overheating of the alternator or additional strain on the alternator belt.
- Battery monitor - Peukert constant should be set to 1.04 (1.25 for lead acid).

Installation Considerations

- Ideally, all battery cables should be the same length so the resistance is equal.
- A T-class fuse should be installed directly to the battery terminal per ABYC.
- All positive wires should be fused near the battery bank per ABYC.
- All batteries should be within 5% State of Charge before connecting together. All batteries at 80% to 100% SOC when connecting is ideal.
- Lead acid or AGM batteries **should not** be connected with LiFePO4 batteries.
- An alternator protector is cheap insurance to protect alternator diodes.

Operating Considerations

- **Battery Balancing** – Multiple batteries wired in parallel will get out of balance after several hundred cycles.
 - Why? – Each battery has an internal resistance.
 - The battery with the lowest internal resistance will charge and discharge faster than the batteries with higher internal resistance.
- **BMS Calibration** - A battery BMS often requires recalibration after several hundred cycles; especially when batteries are wired in parallel.
 - To recalibrate a battery, simply fully discharge and fully charge it.
 - New batteries may require two full charge/discharge cycles to calibrate the BMS.

It has been observed that more cycles on a parallel battery bank result in faster balancing and less requirement for calibration.

Operating Considerations

- **Sleeping BMS** – A BMS may go to sleep after a period of inactivity to conserve battery power.
 - Three ways to wake up a BMS
 - Apply a charge (not a good option on a boat)
 - Apply a discharge
 - Press a reset button on the top of the battery
- **Operating Temperature** – For operation in cold harsh environments a battery can be equipped with a blanket heater.
 - The heater is activated when the battery is below operating temperature and a charge is applied. Once the battery is warmed to a safe operating temperature the BMS is activated and the charge is applied to the cells.

Parameters for Charging LiFePO4 Batteries

If a “LiFePO4” setting is not available on your controller, use the “USER” function to program and set the following parameters:

- **Absorption voltage:** 14.0 volts (acceptable range is 13.6V to 14.4V, 28.0V to 28.8V)
- **Absorption Time:** The recommended setting is .3 to .5 hours per 100ah of LiFePO4 battery
 - (for example: for 2 -100ah batteries select .6 to 1 hour).
- **Float Voltage:** 13.5 volts (13.6 volts or lower is acceptable for LiFePO4 batteries although float is not necessary)
- **Equalization voltage:** **Do not** equalize LiFePO4, turn off the equalize function, but in case it ever runs a cycle or equalization can't be turned off, set to 14.0 volts or less.
- **Temperature Compensation:** LiFePO4 batteries do not need temperature compensation.
- **Low Temperature cut-off:** -5 degrees C, 20 degrees F

Things to Unlearn When Moving from Lead Acid to LiFePO4 Marine Batteries

- **Constant Voltage** - Voltage does not reflect the State of Charge.
- **Battery Charging** – Charging to full is not necessary. 95% of power rating is available, not just top 50%.
- **Battery Charging** – Short absorption stage, no equalization, float stage is not necessary.
- **State of Charge** – 50% State of Charge is fine. 45% of power is still available.
- **Faster more efficient charging** – More power is stored faster.
- **Discharging** – Constant discharge voltage so appliances run more efficiently resulting in decreased power usage.
- **Maintenance** – No toxicity. No water level to check, no heat to be concerned about.
- **Easy Winter Storage** – Simply disconnect until next season.
- **Easy Monitoring** – Bluetooth app displays SoC and power remaining anytime from Smartphone or tablet.

Summary

What to Look for When Purchasing LiFePO4 Batteries

- Quality of the LFP cells (Lithium Iron Phosphate)
- Quality and functionality of the BMS (Battery Management System)
- Capability of BMS Internal and external balancing algorithms
- Continuous Discharge Rate, peak discharge rate
(minimum of 1C or 100A C - Ah capacity, we prefer 150-200A)
- Determine how many batteries can be wired in series or parallel
- Battery monitor - Bluetooth and/or built in meter
- Compatibility with existing chargers and controllers
- Battery reset or wake up button
- Heater
- CAN Bus or NMEA 2000 port
- Replaceable BMS
- Warranty – battery exchange
- Support

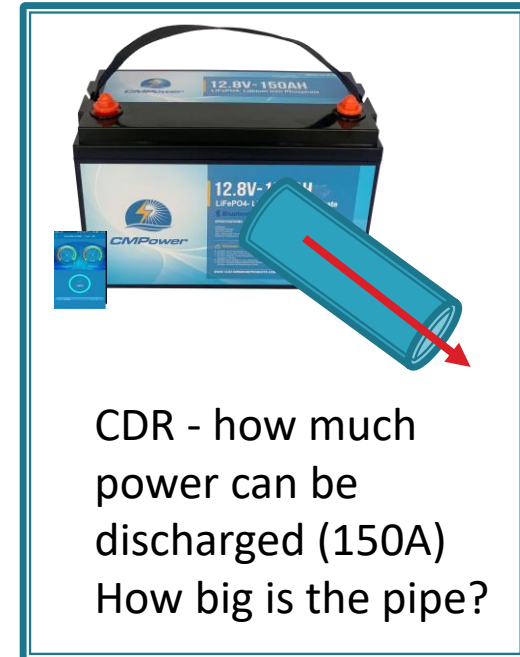

Specifications

Capacity

Ah - Amp Hours

V - Volts

Wh - Watt hours

Performance

A - Continuous discharge amps

Specifications



Model - Part Number	Voltage	Capacity Amp Hours	Watt Hours	BMS Continuous Draw Amps	Group Size	Size Inches	Weight lbs.	Price
Marine High Power Density Series								
12 Volt								
CMP205120-BH150	12.8	120	1,536	150A	24	10.25x6.7x8.2	29.0	\$ 1,079
CMP205135-BH150	12.8	135	1,728	150 A	27	12x6.7x8.3	31.0	\$ 1,198
CMP205150-BH150	12.8	150	1,920	150A	31	13x6.8x8.9	33.0	\$ 1,299
CMP205240-BH200	12.8	240	3,072	200A	49-4D	19.3x6.7x9.4	45.0	\$ 2,095
CMP205350-BH200	12.8	350	4,480	200A	8D	20.75x11.2x10	60.0	\$ 2,795

Marine High Power Density Series -Removable BMS								
12 Volt								
CMP205135-BHR150	12.8	135	1,728	150 A	27	12x6.7x8.3	31.0	\$ 1,198
CMP205150-BHR150	12.8	150	1,920	150A	31	13x6.8x8.9	33.0	\$ 1,299
CMP205225-BHR200	12.8	225	2,880	200A	49-4D	19.3x6.7x9.4	45.0	\$ 1,995
CMP205313-BHR200	12.8	315	4,032	200A	8D	20.75x11.2x10	58.4	\$ 2,695
24 Volt								
CMP206150-BHR150	25.6	150	3,840	150A	8D	20.75x11.2x10	80.0	\$ 2,598

Below is contact information should you have questions or comments.



Custom Marine Products
custommarineproducts.com
Tom Trimmer

tom@custommarineproducts.com

248 705 8337





Q & A



Advantages of LiFePO4 Marine Batteries vs. Lead Acid Batteries

- Lighter than lead acid or AGM (half the weight - 4x energy density)
- Can be drawn down 95% vs 50% (double the usable power)
- Hold a steady voltage through 95% discharge (appliances run more efficiently)
- Generally plug compatible with lead acid chargers (easy installation)
- Charge more quickly than lead acid (less charging time)
- Charge more efficiently than lead acid (ideal for solar and wind generation)

Advantages of LiFePO4 Marine Batteries vs. Lead Acid Batteries

- Up to 10 times more charge cycles than lead acid (could last a lifetime +)
- Cost per charge cycle: SLA \$1 LiFePO4 \$.15
- Nontoxic and safe (very low fire risk, no fumes or acid)
- Low self-discharge (easy winter storage)
- Bluetooth battery monitor built in (accurate State of Charge data)
- Environmentally friendly (no toxic chemicals or heavy metals)

Disadvantages of LiFePO4 Marine Batteries

- Operating temperature range (lead acid can operate at lower temps)
Discharging below -4F will reduce cycle life
- Some chargers are not compatible (additional equipment expense)
- Increased alternator loading
- Initial investment is higher than lead acid (advantages and longevity significant)
(concept of a Battery Exchange)

Cost per charge cycle: SLA \$1 LiFePO4 \$.15