

## Wiring Your Solar System

The electrical portion of the kit includes a controller, remote display meter (optional), coil of solar wire with MC4 connectors, and an MC4 T-branch connector (two panels or more). The solar wire comes in a coil with a male and a female MC4 connector preinstalled on each end.

**Refer to wiring diagrams on the last page.**

1. Determine the location of the solar controller and the remote display meter (if included) and mount them as appropriate. The meter should be mounted where it is readily visible.
2. Determine the length of wire needed to run from the solar panels to the controller. Cut the wire in half or to whatever length needed. The ends with the MC4 connectors attach to the panels and the other end attaches to the controller.
3. Run two lengths of the solar wire from the solar panels to the controller. The preinstalled MC4 connectors will be at the solar panels.
4. Connect the solar panels in parallel using the T-branch MC4 connectors. Assuming a two panel system, plug in the two positive wires from the solar panels to the T-branch. Plug in the two negative wires from the solar panels to the other T-branch. Plug the T-branch connector into the MC4 connectors on the wires running to the controller.
5. Optional – We recommend a switch be placed in the positive wire running from solar panels to the controller. This switch is used to shut down the system if desired. The switch should be rated at least for the total amperage of the solar array.
6. Connect the remote display meter to the controller using the wire included with the display. Simply plug the meter into the controller and to the display.
7. Connect the controller to the battery bank or banks if you have the dual output controller. Strip off about 3/8" from the end of the wires leading from the battery bank(s) to the controller. Solar wire or other 10-gauge wire can be used for this. A fuse greater than the rated output of the controller on the positive line from the battery bank to the controller is recommended.
  - a. Note: If you have a battery monitor like a Xantrex Link 1000 on board, attach the negative wire from the controller to the house side of the battery monitor shunt not to battery bank.
  - b. The controller is connected to the battery bank first then the solar panel wires are connected. This is because the controller is powered by the battery bank not the solar panels.
8. Strip off about 3/8" from the end of the solar wires leading from the solar panels to the controller. Insert these wires directly into the terminals of the controller and secure by tightening the screws on the controller. **Do not attach the wires to the controller until**

**the controller is attached to the battery bank(s). Be certain the positive wire from the solar panel array is inserted into the positive terminal on the controller. It is suggested that the polarity of the wires be tested with a meter before inserting into the controller.**

9. The LOAD function available with the Tracer and XTRA controllers is not used for our marine battery charging application.
10. Program the controller per the instructions that come with the controller and display. Use the display to program the Tracer BN controller or the button on the controller for the Dual Output controller.
  - a. Note: If your controller has a LOAD feature, just ignore it. You do not need that function for the marine battery charging application.
  - b. See below for summary of instructions to program the controllers.
11. Your solar system should be operational. Hope you get a charge out of it!

Note: The solar controller will only feed the batteries to a charge level they can accept. Your display will show the voltage and amperage or wattage being provided to your battery bank(s). If your batteries are near full state of charge, the controller automatically cuts back on the charging power and reflects that on the display even though the panels have the capacity to provide more charging power.

## **Programming a Tracer BN or XTRA Solar Controller from the Meter**

The key parameters to program on this display are the **battery type, the battery bank amp hours, the date and the time**. Other parameters such as length of time the back light is on, can be found in the manual.

1. Esc            left most button
2. Down        to 4. Control Para
3. OK            right most button
4. OK            skip password
5. UP, DOWN    to battery type
6. RIGHT        to Battery Amp Hours
7. UP,DOWN    on each digit
8. OK            Save
9. OK            Save success message
10. Esc          to Menu
11. DOWN        to 6. Device Para
12. OK
13. DOWN        to Backlight and Date
14. OK            to set
15. RIGHT        to Date and Time

- |             |  |
|-------------|--|
| 16. UP,DOWN | to set   |
| 17. RIGHT   | to next digit  |
| 18. OK      | Save   |
| 19. OK      | Save success message   |
| 20. Esc     | to Menu  |
| 21. OK      | 1. Monitoring  |
| 22. UP,DOWN | for monitoring pages (first page with graphics and page with Watt Hrs are most used) |

## Programming the EP Duo dual output controller

There are three parameters to program from the button on the controller. These are the **battery type, the percentage of charge to each battery bank and the charging frequency**. The default charging frequency is fine as programmed. Change the frequency only if the controller is interfering with radio transmission.

1. The programming button is to the upper right on the front of the controller. Select the setting you wish to change by pressing the Programming Button. A red LED light will indicate which of the three settings is selected. • Battery type • Battery bank charging priority • Charging frequency
2. Press the Programming Button for 5 seconds until the value of the selected setting is displayed.
3. Press the Programming Button as many times as necessary to select the value desired. The values are highlighted on the top of the controller.
4. Wait 3 seconds until the LED light turns off. The value will be saved by the system.
5. Repeat steps 1-4 to program another setting.

## Caring for Your Solar Panels

1. Clean panels with water and a non-abrasive cloth. Mild soap may be used.
2. Use caution when transporting the panels.
3. Do not bend beyond 30 degrees.
4. Observe proper polarity when connecting the modules into the electrical circuit. Reverse polarity will damage the module.
5. Do not carry the module by the wires.
6. Do not scratch, cut or puncture the module.
7. Do not walk on the module.

These instructions are on the web site under SUPPORT, MANUALS & INFO

# Wiring Diagram Examples

Single Solar Panel Installation with Dual Output Controller Charging Two Battery Banks

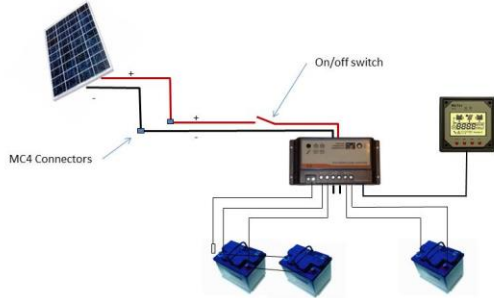

Attach controller to battery banks first and to solar panels second.

custommarineproducts.com

Two Solar Panels Wired in Parallel with Dual Output Controller Charging Two Battery Banks

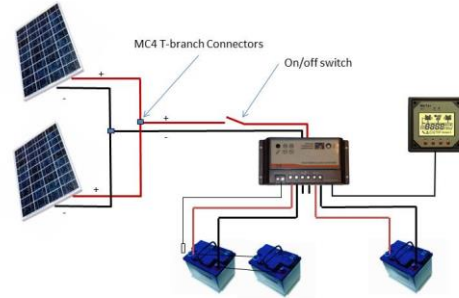

Attach controller to battery banks first and to solar panels second.

custommarineproducts.com

Three Solar Panels Wired in Parallel with One EP Tracer BN MPPT Controller

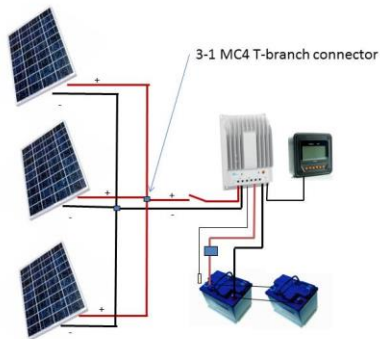

Note: If a battery monitor is installed, negative wire from controller should be connected to the house side of the battery monitor shunt, not the battery bank.

custommarineproducts.com

Four Solar Panels Wired in Parallel with One EP Tracer BN MPPT Controller

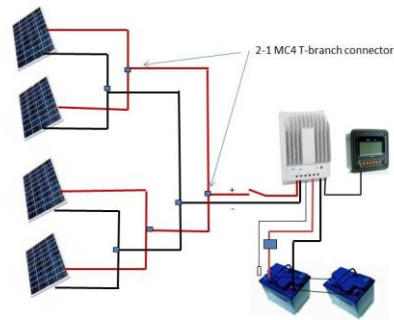

Note: If a battery monitor is installed, negative wire from controller should be connected to the house side of the battery monitor shunt, not the battery bank.

custommarineproducts.com

Four Solar Panels Wired Two in Series and Group in Parallel with EP Tracer BN MPPT Controller

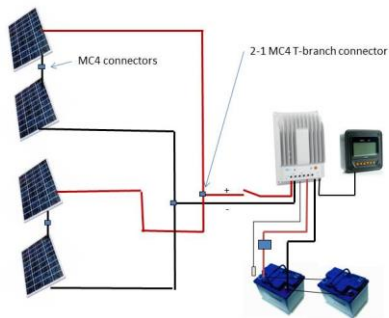

Note: If a battery monitor is installed, negative wire from controller should be connected to the house side of the battery monitor shunt, not the battery bank.

custommarineproducts.com

Four Solar Panels Wired in Parallel with Two EP Tracer BN MPPT Controllers

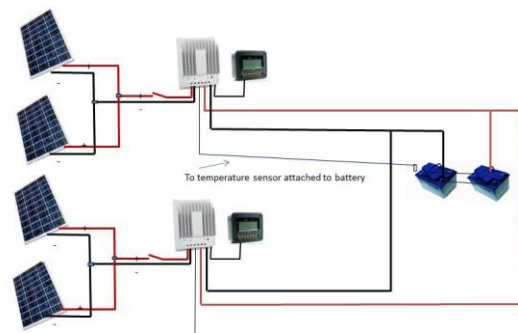

custommarineproducts.com