

Instruction Manual

Duo-battery Solar Panel Controller
EPIP20-DB series
For Both 10 and 20 amp. Controllers
(for use with solar panels only)

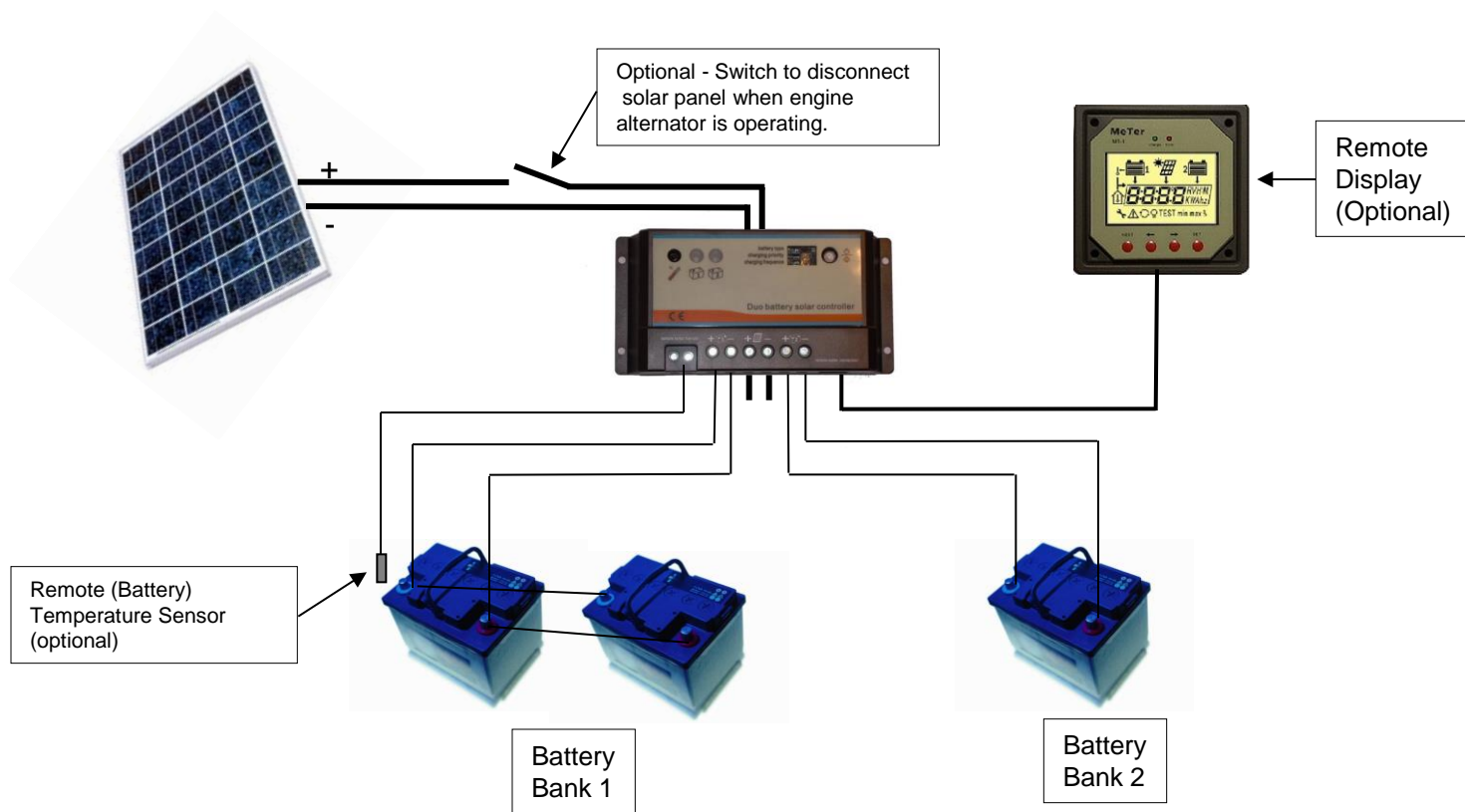

Note: If using a battery monitor such as a Link 10 or 20, connect negative wire from controller to the shunt rather than negative side of battery.

Specifications:

Set point (12V)	Sealed Battery	Flooded Battery	Gel Battery
Regulation voltage	14.2V	14.4V	14.6V
Boost voltage	14.4V	14.6V	14.8V
Float voltage	13.7V	13.7V	13.7V
Maximum solar voltage	30V(or 55V)		
Battery voltage range	1-15V		
Boost time	30 minutes		
Power consumption	4mA at night, 10mA at charging		
Meter bus connection	8 pin RJ-45		
Temp. compensation	-30mV/12V		
Terminals	4mm2		
Temperature	-35 C to +55 C (-31 F to +131 F)		
Min. Operating Voltage	8 volts		

Note:

Unit will automatically sense 12V or 24V
For 24V set point, multiply values by 2

Installation:

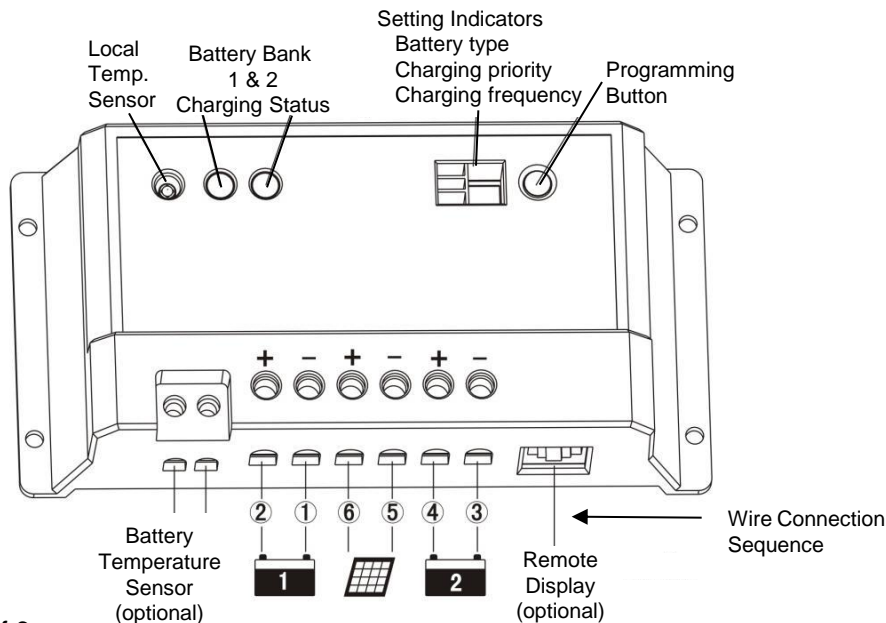

Connect wires in sequence shown in diagram

- Connect battery bank #1
- Connect battery bank #2
- Connect solar panel

Attach remote temperature sensor to the top of a battery in battery bank #1

The Remote Display (optional) and the Remote Temperature Sensor (optional) can be connected to the Charge Controller at anytime.

Programming the Duo-battery Charge Controller

1. Select the setting you wish to change by pressing the Programming Button. A red LED light will indicate which of the three settings is selected.
 - Battery type
 - Battery bank charging priority
 - Charging frequency
2. Press the Programming Button for 5 seconds until the value of the selected setting is displayed.
3. Press the Programming Button as many times as necessary to select the value desired.
4. Wait 3 seconds until the LED light turns off. The value will be saved by the system.
5. Repeat steps 1-4 to program another setting.

Battery Type (LED #1):

Value	Battery Type
1	Sealed battery (pre-set)
2	Gel battery
3	Flooded Battery

Charging Frequency (LED #3):

Value	PWM Charging Frequency
0	25 Hz (pre-set)
1	50 Hz
2	100 Hz

Battery Bank Charging Priority (LED #2):

Value	Bank #1	Bank #2
0	0%	100%
1	10%	90%
2	20%	80%
3	30%	70%
4	40%	60%
5	50%	50%
6	60%	40%
7	70%	30%
8	80%	20%
9	90%	10%

In the normal charging mode, the controller will divide the charging per the setting. When battery bank #1 is fully charged, the charging current will be diverted to battery bank #2. The controller will automatically return to the charge priority when battery bank #1 is at a lower voltage.

When the controller detects there is only battery bank #1, all the charging will go to that bank automatically.

Troubleshooting

1. LED blinking – Short circuit. Check solar panel and battery connections.
2. LED slowly flashing – Batteries are fully charged.
3. LED on - Charging
4. LED frequent flashing – no charging.
5. LED off – no battery or over voltage.

Controller Dimensions

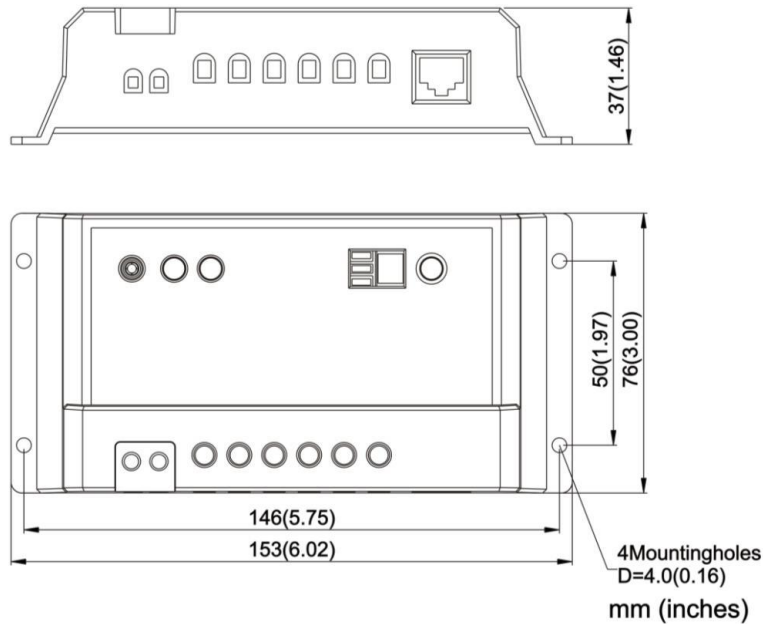

Instruction Manual

Remote Display for Duo-battery Solar Panel Controller EPIP20-DB series

The Remote Display provides data on the operating performance of the solar panel(s), the status of the battery banks being charged and system diagnostic data. Data available on the Remote Display includes the following:

Solar Panel

- Output voltage
- Output amperage
- Max amperage output
- Cumulative amp hours generated

Each Battery Bank

- Current voltage
- Minimum voltage
- Maximum voltage
- Cumulative amp hours

Diagnostic Data

- Bank Charging Priority
- Current time
- Charging frequency
- Local (ambient) Temperature
- Battery bank #1 temperature

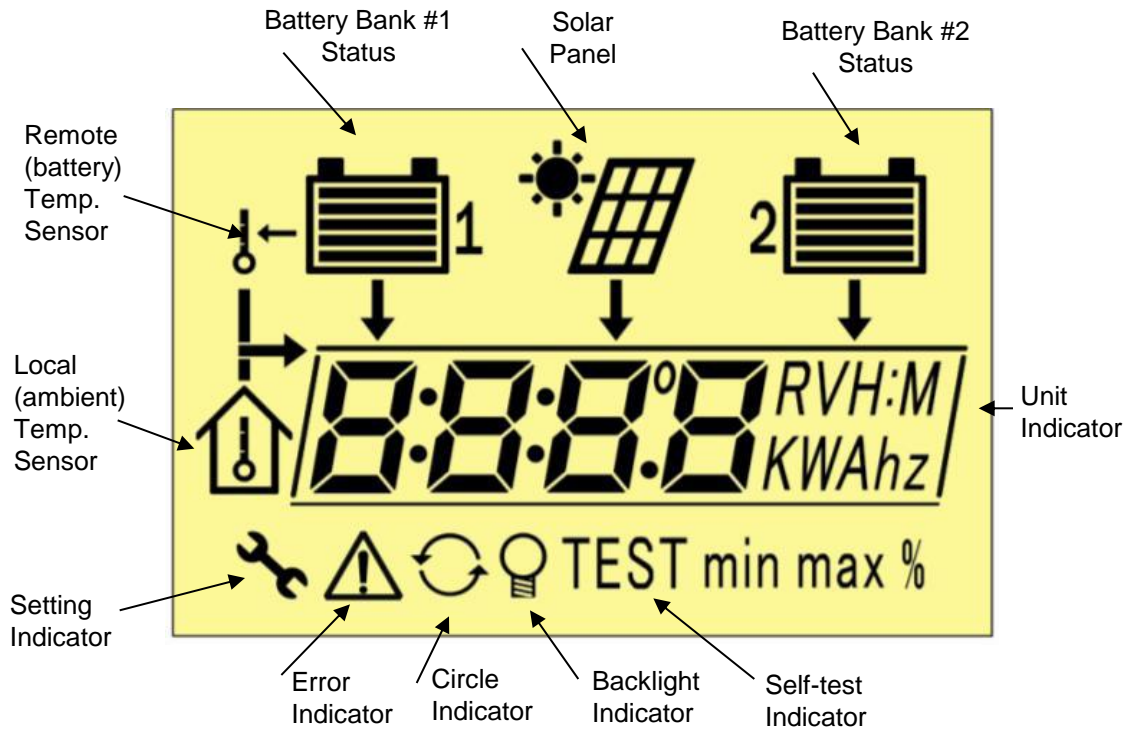
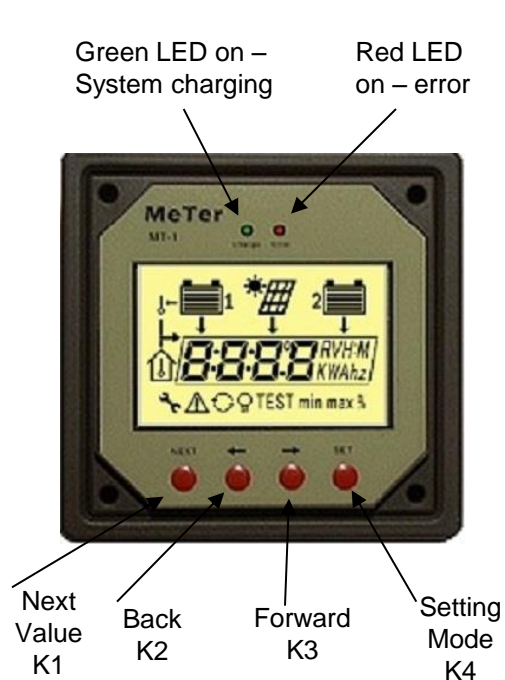

Operating Instructions

The Remote Display provides four sets of operating and diagnostic data.

1. Solar panel performance
2. Battery bank #1 status
3. Battery bank #2 status (if connected)
4. Temperature and time data

Press the NEXT button to select one of the four data sets. Press the FORWARD or BACKWARD buttons to select the specific data value desired. If the DATA REPEAT option is set to AUTO, the display will automatically move to the next data value every 3 seconds.

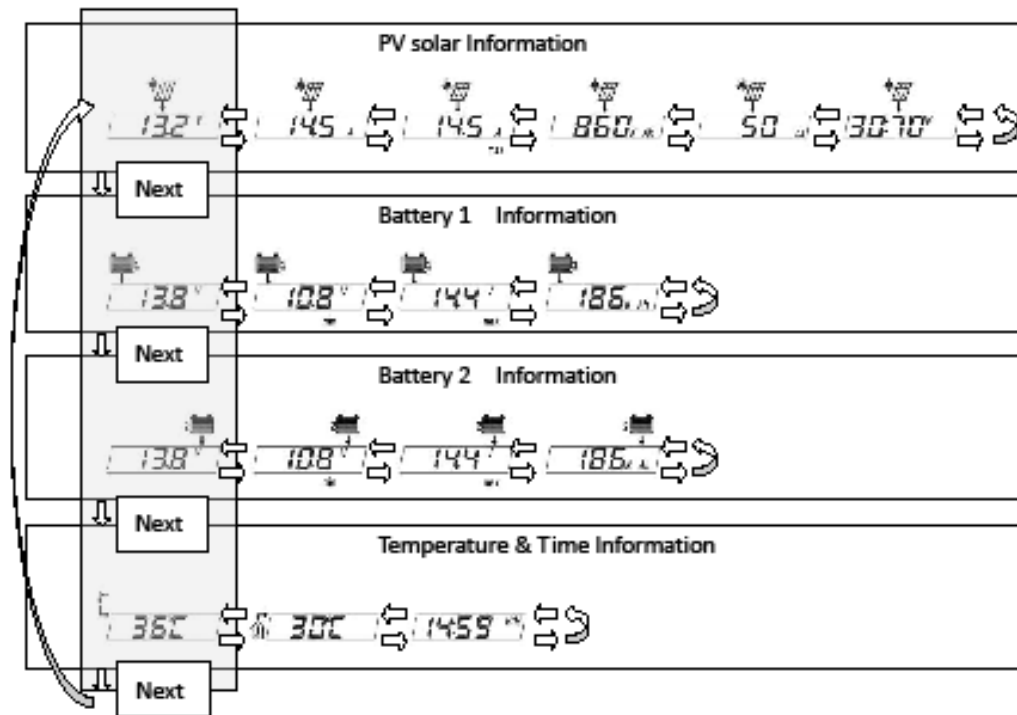

Setting the Display Operating Parameters

Remote Display operating parameters can be programmed using the SET button on the far right of the display.

These parameters include:

Temperature Units (C or F)

Backlight timer

Backlight brightness

Data repeat option

Time (24 hour clock)

Press the SET button (K4) to enter setting modification mode. Use the NEXT button (K1) to select the data to be edited. Use the FORWARD and BACK buttons (K2 and K3) to modify the data. Press the SET button (K4) to save the value.

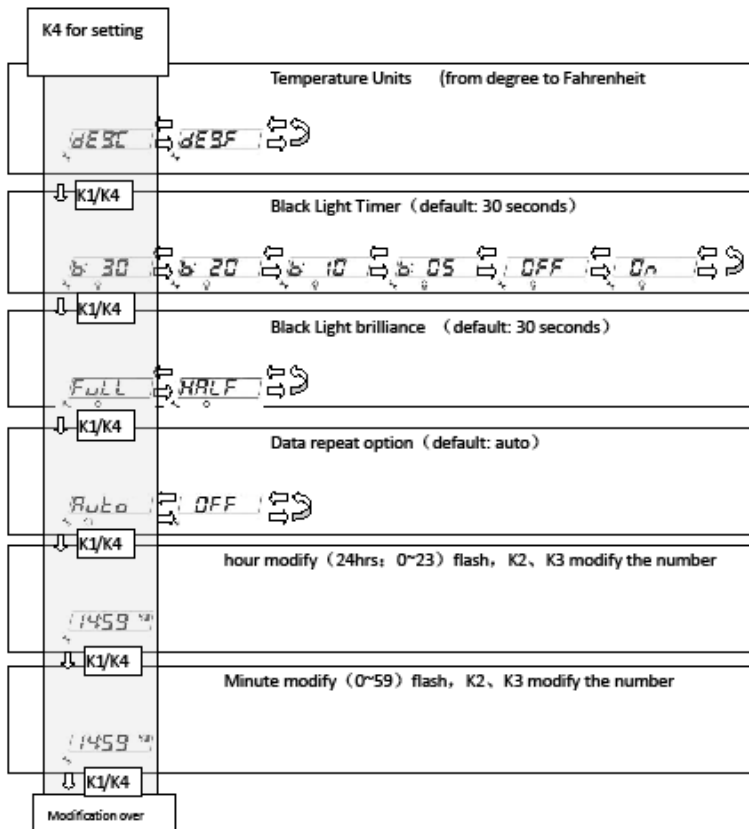

Temperature Units: Centigrade (**C**) or Fahrenheit (**F**)

Backlight Timer: Pressing any key will turn on the backlight. The backlight timer controls how long the backlight will stay on.

Backlight options include:

OFF: backlight is always off

On: backlight is always on

B: 30 backlight on for 30 seconds (pre-set)

B: 20 backlight on for 20 seconds

B: 10 backlight on for 10 seconds

B: 05 backlight on for 5 seconds

Backlight brightness:

FULL bright

HALF dim

Data repeat:

Auto the display will advance to the next data value every 3 seconds unless the FORWARD or BACK buttons are pressed.

OFF the display will not advance automatically.

Time: the 24 hour clock can be set for both hours and minutes.

Additional Operating Instructions

System Diagnostics: System diagnostics can be displayed by pressing the BACK and SET buttons (K3 and K4) together. Data displayed includes: battery connection, solar panel connection and temperature sensor connection. A **no** or **OPEn** value indicates the item is not connected. The display will automatically advance to each data value or the FORWARD and BACK buttons can be used to advance to each data value.

Resetting Data Values: Values for max and min voltage and amp hours (AH) can be reset to zero at any time by pressing the NEXT and BACK buttons (K1 and K2) together. Alternatively, disconnect and reconnect the display unit.

Battery Bank Status Bars: Each bar on the display battery icon represents 20% of the battery charge. The bars are calculated based on battery bank voltage, not actual battery capacity. A flashing top bar indicates battery overcharge.

Trouble indicator on: The following conditions may occur, check the connection.

1. One battery bank disconnected, open circuit, or over voltage.
2. The remote temperature sensor is no connected or not working.
3. Solar panel current exceeds rated limit for controller.
4. Solar panel has a short-circuit.

Operating Specifications

Rated voltage:	12V, min voltage: 8.0V.
Power Consumption:	
Low backlight on:	<23mA
Strong backlight on:	<20mA
Backlight and LED indicator off:	<17mA
Working temperature:	-15 C ~ +40 C (5 F to 104 F) (Data may be incorrect when out of temperature range.)
Humidity:	0-100%
Communication cable:	RJ45(8PIN), 10 meters (32 ft.) in length.
Data update rate:	Every 20 seconds